



ALPINE ACV SERIES

Alpine Pressure Reducing Control Valve IOM Manual



Pressure Reducing
Pilot P200

Installation, Operating and Maintenance Manual – BT115 Pressure Reducing Valve

Address: 272 Bath Street Glasgow G2 4JR **Cell:** +44 (0) 776348 8809: **Land:** +44 (0) 1369
760423: **Email:** john@afcvalves.co.uk: **Web:** www.afcvalves.co.uk



ULTRA / ALPINE SERIES

BT115 – Pressure Reducing valve

LEGEND

- 1 Upstream Ball Valve
- 2 Y Strainer
- 3 Upstream Gauge
- 4 Flow controller
- 5 Pressure Reducing Pilot Valve TEYI
- 6 Downstream Gauge
- 7 Downstream Ball Valve

Note U.C.V. may have an added feature of a bonnet ball valve which when in the closed position freezes the valve in its set position. Enabling work to be done on the control loop without closing the pipe line. This must remain open during normal operations

Control Loop

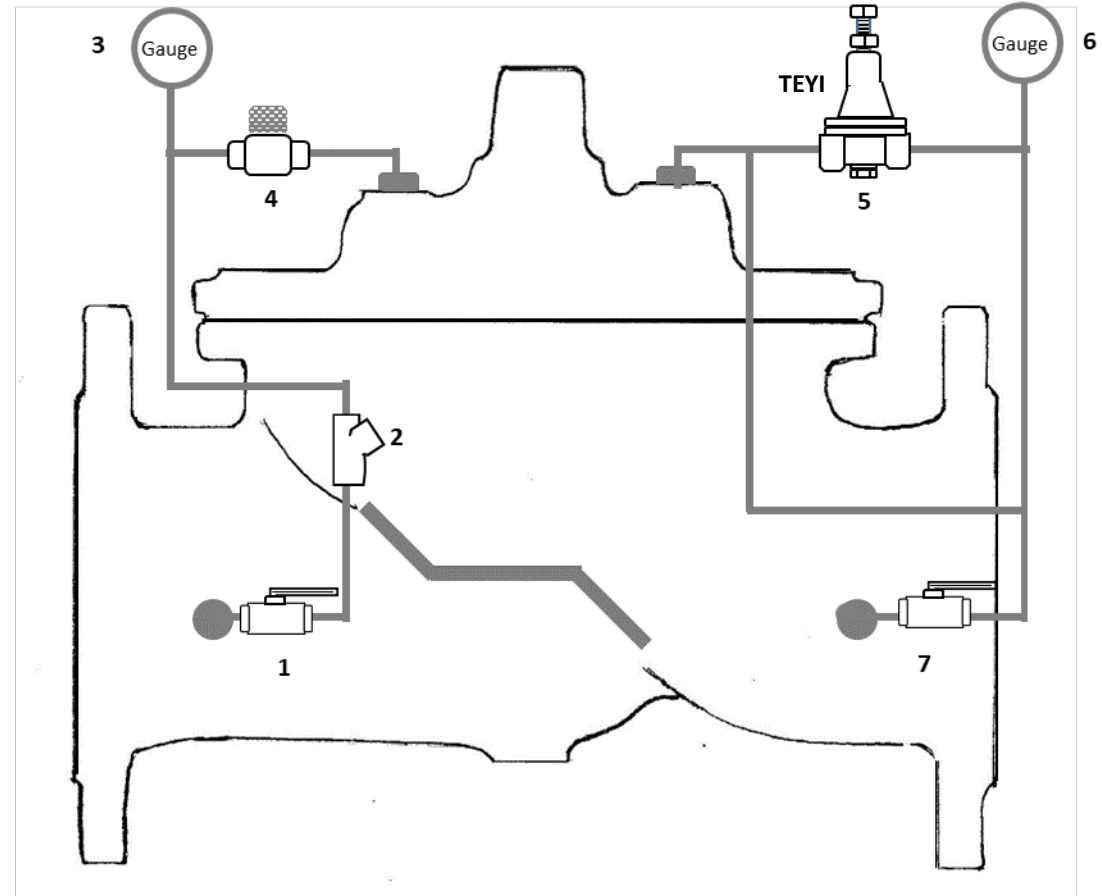

FUNCTION :

Automatically reduces a fluctuating higher inlet pressure to a constant lower outlet pressure regardless of changing flow rate and/or varying inlet pressure

CONSIDERATIONS :

- Ultra Pressure reducing valves have a 4:1 cavitation ratio Reduced bore & 3:1 for a full bore, this must be taken into consideration when setting the valve i.e. If the upstream pressure is 20 bar the lowest you can set the valve is 5/7 bar.
- If the inlet pressure is too high an Ultra Ratio reducing valve should be installed upstream of the pressure reducing valve. Alternatively an anti –cavitation trim
- As the object of a pressure reducing valve is to protect the downstream pipeline and fittings, its always wise to install a Relief valve downstream of the PRV.
- To set a PRV you need both downstream flow and back pressure. Without flow the PRV will equalise without back pressure the pilot will not react.

COMMISSIONING : Refer to drawing No 1

- Close the mainline upstream and downstream isolating valves on either side of the control valve.
- Set the flow controller (No 4) to the halfway position (Clockwise closing) This valve controls the closing speed of the valve. (i.e. the more you close it the slower the valve closes).
- Close the downstream ball valve (No 7).
- Slowly open the upstream mainline isolating valve.
- Bleed off all accumulated air trapped inside the valve bonnet by loosening one of the gland nuts at the highest point on the valve.
- Turn the adjustment screw of the PRV pilot (No 5) all the way out (anti-clockwise) until there is no tension on the spring.
- Open the mainline downstream isolating valve. The valve should remain in the closed position.
- Slowly open the downstream ball valve (No 7). The valve should still remain closed.
- Slowly Turn the adjustment screw of the PRV pilot (No 5) in (clockwise). The valve will start opening.
- As you turn the adjustment screw of the PRV in, the pressure reading on the downstream gauge will increase.
- If it stops increasing before the required downstream pressure is reached, turn the adjustment screw back out again until control is regained.
- Wait until the line fills then turn the adjustment screw back in, until the required downstream pressure is reached.

NOTE: If while setting the PRV pilot the downstream pressure suddenly matches the upstream pressure, it means there is insufficient downstream flow and the valve has equalized, open a discharge valve downstream until you get more flow downstream, then carry on setting the PRV pilot.

If the PRV pilot refuses to react while setting, The back pressure is too low, close one of the downstream valves until the PRV pilot reacts, then set the PRV pilot to the required pressure, when the pilot is set, re-open the downstream valve.

Drawing No 2

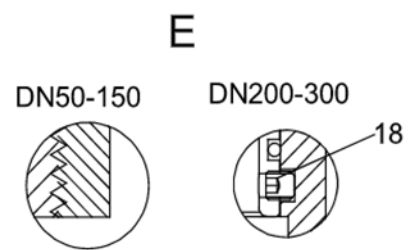
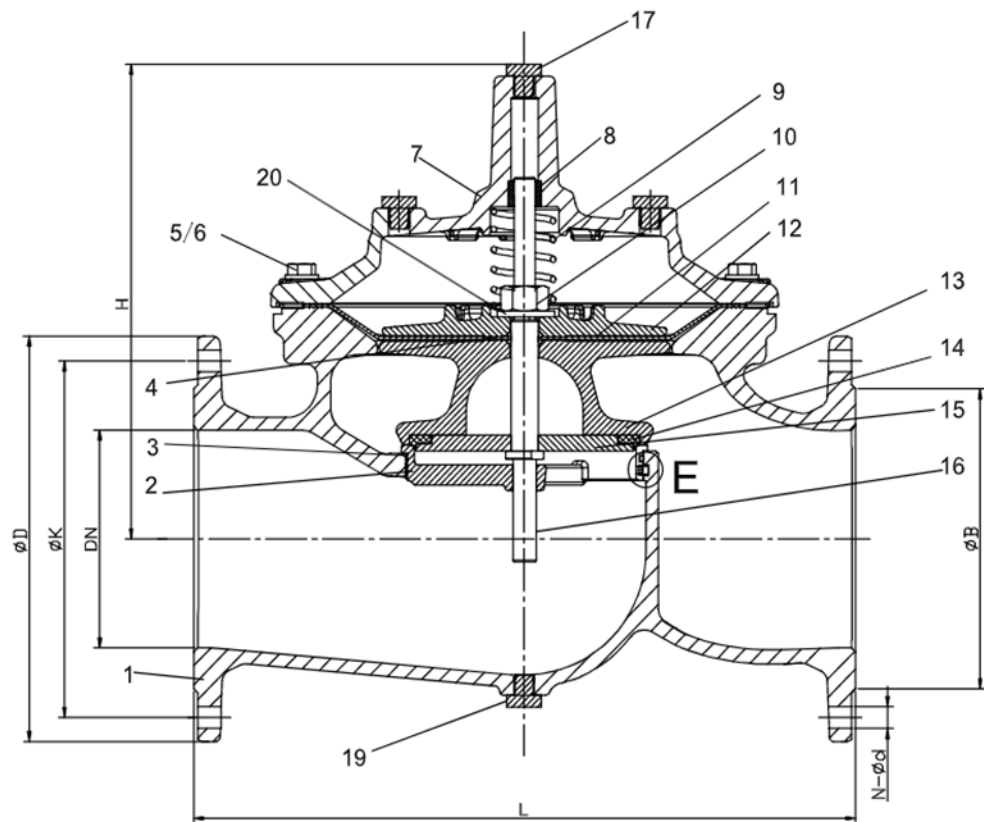

PARTS LIST - SPECIFICATIONS

No	Description	Material	Standard
1	Body	Ductile Iron	GJS 500 – 7
2	Seat	Stainless Steel	AISI 304 / 316
3	O-ring	Rubber	NBR
4	O-ring	Rubber	NBR
5	Bolt	Stainless Steel	A2 / A4
6	Washer	Stainless Steel	A2 / A4
7	Bonnet	Ductile Iron	GJS 500 – 7
8	Bush	Bronze	C61900
9	Spring	Stainless Steel	AISI 304 / 316
10	Caulking Nut	Stainless Steel	A4
11	Diaphragm	Nylon Reinforced Rubber	EPDM + Nylon Fabric
12	Fixing Holder	Ductile Iron	GJS 500 – 7
13	Disc Holder	Ductile Iron	GJS 500 – 7
14	Seal	Rubber	EPDM
15	Seal Retainer	Stainless Steel	AISI 304 / 316
16	Stem	Stainless Steel	AISI 304 / 316
17	Plug	Stainless Steel	AISI 304 / 316
18	Screw	Stainless Steel	A2 / A4
19	Plug	Stainless Steel	A2 / A4
20	Washer	Stainless Steel	A2 / A4

MAINTENANCE (Refer Drawing No 2)

The Ultra PRV needs periodic maintenance of 1 – 2 years depending on the severity of operating conditions

N.B. Make sure there is no pressure In or directly upstream of the valve - Use the mainline isolating valves to ensure personnel safety

- Check the tightness of the Control Loop fittings
- Check the flanges for leaks
- Remove the bonnet and check the diaphragm (11) for Rips or damage
- Lift the diaphragm assembly out
- Check the O Rings (3 & 4) and seal (14)
- Check the Disc Holder (13) for cavitation wear

TROUBLE SHOOTING GUIDE

Valve refuses to open

- Stem Jammed or blockage on top of stem
- Blockage on the downstream Control Loop
- Leak on the upstream Control Loop
- Diaphragm torn
- Downstream ball valve closed
- PRV Pilot blocked or damaged
- Low upstream pressure

Valve Refuses to close

- * Debris underneath the stem
- Blockage on the upstream Control Loop
- Leak on the downstream Control Loop
- Torn Diaphragm
- Upstream ball valve closed