



Alpine Flow Control UK

Wide range ductile iron repair clamp PN10/PN16

repair clamp standard: comply with EN545

Coating standard: EN30677

Test standard: EN12266-1

Working pressure and Temperature.

size DN80 to DN300, Working pressure PN10/PN16

Temperature from -10°C to 120°C for EPDM gasket

Temperature from -10°C to 82°C for NBR gasket



Connection for PVC, HDPE, DI, steel GRP etc pipe which pipe OD is in our repair clamp range

suitable for potable water, neutral liquids and sewage

WRAS approved is available upon request

Material specification

Sr.No.	Name	Material
1	Body	Ductile Iron
2	Gasket	EPDM
3	Bolts	Grade 4.8 Gal. carbon steel
4	Nuts	Grade 4.8 Gal. carbon steel

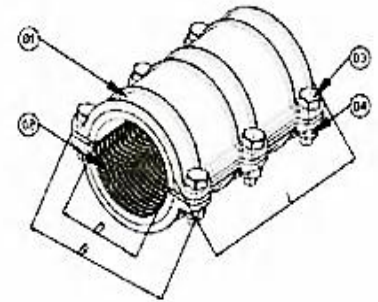

Options: Grade 4.8/6.8/8.8 carbon steel bolts with galvanization/dacromet/teflon etc

Stainless steel SS304/SS316/SS316L/A2/A4 etc bolts

FBE coating and Nylon 11 coating is available

DN	D	L	B
80	88-99	225	219
100	107-119	225	246
150	157-171	225	291
200	219-226	310	352
250	270-276	310	420
300	320-328	310	471

Please note dimension may vary at our discretion