



# Alpine Flow Control UK

## Restrained flange adaptor for HDPE pipe PN10/PN16

restrained flange adaptor standard: comply with EN545

Coating standard: EN30677

Test standard: EN12266-1

Flange type: EN1092-2 PN10/PN16

### Working pressure and Temperature

size DN50 to DN300, Working pressure PN10/PN16

Temperature from -10°C to 120°C for EPDM gasket

Temperature from -10°C to 82°C for NBR gasket

Connection for HDPE pipe

suitable for potable water, neutral liquids and sewage

WRAS approved is available upon request



### Material specification

| Sr.No. | Name         | Material                               |
|--------|--------------|--|
| 1      | Body         | Ductile Iron                           |
| 2      | Sealing ring | EPDM+Brass                             |
| 3      | End ring     | Ductile Iron                           |
| 4      | Bolts        | grade 4.8 dacromet coated carbon steel |
| 5      | Washer       | grade 4.8 dacromet coated carbon steel |
| 6      | Nut          | grade 4.8 dacromet coated carbon steel |
| 7      | Bolt cap     | Plastic                                |

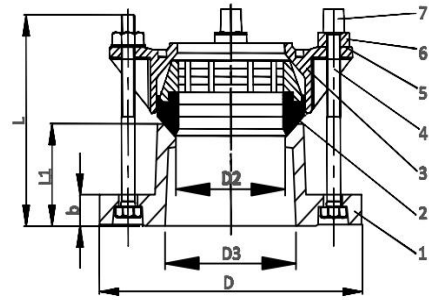

**Options:** Grade 4.8/6.8/8.8 carbon steel bolts with galvanization/dacromet/teflon etc

Stainless steel SS304/SS316/SS316L/A2/A4 etc bolts

FBE coating and Nylon 11 coating is available

| DN       | pipe OD(mm) | D2    | D3  | D   | b  | L1 | L   | Bolts No. |
|----------|-------------|-------|-----|-----|----|----|-----|-----------|
| 50       | 50          | 53.5  | 62  | 165 | 19 | 63 | 110 | M12x2     |
| 50/60/65 | 63          | 67    | 73  | 185 | 19 | 63 | 110 | M12x2     |
| 60/65    | 75          | 79    | 87  | 185 | 19 | 63 | 110 | M12x2     |
| 80       | 90          | 94    | 102 | 200 | 19 | 63 | 110 | M12x4     |
| 100      | 110         | 114   | 122 | 220 | 19 | 63 | 110 | M12x4     |
| 125      | 125         | 129   | 137 | 245 | 19 | 63 | 110 | M12x4     |
| 150      | 160         | 164.5 | 173 | 285 | 19 | 65 | 110 | M12x4     |
| 150      | 180         | 184.5 | 193 | 285 | 19 | 65 | 110 | M12x4     |
| 200      | 200         | 205   | 215 | 340 | 19 | 75 | 120 | M12x4     |
| 200      | 225         | 230   | 239 | 340 | 20 | 75 | 120 | M12x4     |
| 250      | 250         | 255   | 265 | 400 | 22 | 75 | 120 | M12x6     |
| 250      | 280         | 285   | 294 | 400 | 22 | 75 | 120 | M12x6     |
| 300      | 315         | 320   | 329 | 455 | 24 | 85 | 130 | M12x6     |

Please note dimension may vary at our discretion