



# BUTTERFLY VALVE

**SERVICE**

Linuo top quality butterfly valves are suitable for both on/off and throttling service.

The triple offset design incorporates torques in seating for tight shutoff or control even in the roughest applications. Industries where the triple offset butterfly valves are widely used include Power, Refining, Petrochemical, Chemical, and Pulp and Paper.

**FEATURES**

**Shaft Bearings**

Shaft is centered on two self-lubricating bearings with extremely high rotation precision and stability. Bearing is PTFE lined on internal surface on bronze sintered stainless steel base material with super abrasion resistance and self-lubrication to free from seizure problem.

**Compact Construction**

Due to the nature of their design, butterfly valves can offer very short face to face dimensions. Less metal means butterflies are often a very economical alternative to ball valves. Also, reduced torque for butterfly valves offers even more cost savings, as they can be operated with smaller actuators.

**Low Emission Shaft**

Shafts are precisely ground by CNC machine with very fine finish and low friction factor, therefore, low emission from packing and long packing cycle life.

**Various Sealing Design**

Valves are with standard laminated disc seal with graphite layers carefully assembled between stainless steel layers with reliable high temperature resistance and seat tightness. Torque seating during closing of the valve provides friction free sealing for long circle life. Based on suitability of the intended service, seat options may include PTFE seat, metal seat. Consult Linuo with specifics on your application, and we'll be happy to help to select a valve for your service.

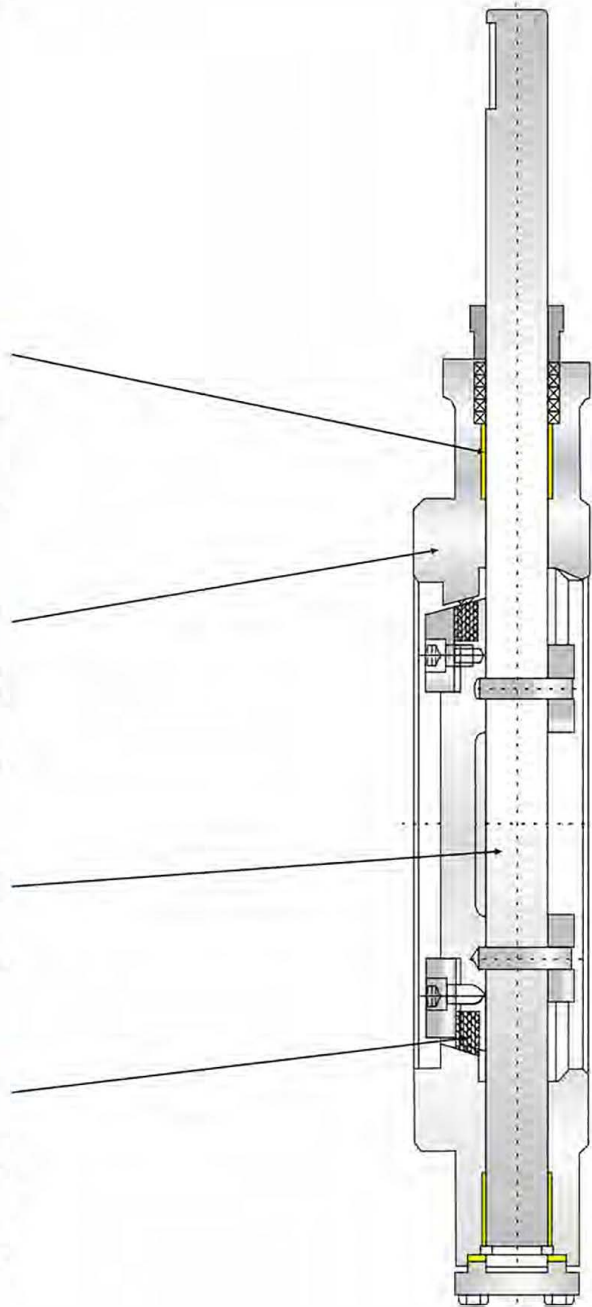

Exploded View

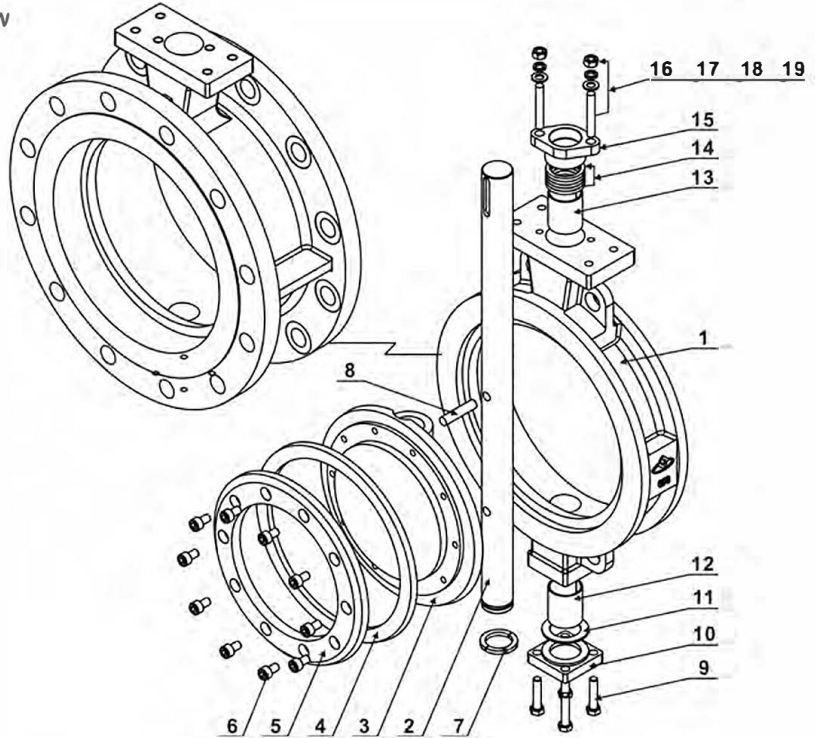

**PARTS LIST / MATERIALS OF CONSTRUCTION**

Table 1

No	Parts	QTY (pc)	Material
1	Body	1	WCB, CF8, CF8M
2	Shaft	1	17-4PH, SS304, SS316, SS410
3	Disc	1	WCB, CF8, CF8M
4	Sealing ring	1	Stainless steel + graphite, PTFE
5	Retainer flange	1	Carbon Steel, SS304, SS316
6	Hexagon bolt	as required	SS304, SS316
7	Split Collar	1	SS304, SS316
8	Pin	2	SS304, SS316
9	Hexagon bolt	4	SS304
10	Blind flange	1	WCB, CF8, CF8M
11	Gasket	1	Spiral wound metal/graphite gasket
12	Self-lubricating bearing	1	Composite material
13	Self-lubricating bearing	1	Composite material
14	Packing	as required	PTFE, flexible graphite
15	Gland	1	WCB, CF8, CF8M
16	Stud	2	SS304
17	Washer	2	SS304
18	Spring Washer	2	SS304
19	Nut	2	SS304

## TECHNICAL SPECIFICATIONS

Nominal Diameter: DN50-DN1200 2 inch-48 inch

Pressure Rating: PN10-PN40, ANSI150, ANSI300

Connection Type: Wafer, Lug, Flanged

Working Temperature: -40°C ~ +160°C / -40°F ~ +320°F for PTFE seat  
 -40°C ~ +425°C / -40°F ~ +797°F for metal seat

For temperature exceeds the above ranges, please consult Linuo factory.

Design and manufacture standard: API609

Face-to-face dimensions standard: API609 for flanged type, EN558.1 for wafer and lug type.

Seat tightness: Control valve-ANSI/FCI 70.2-2006 Class V

On/Off Valve-ISO 5208 rate D for metal seat, ISO 5208 rate A for soft seat.

For higher tightness requirement, please consult Linuo factory

## FLOW CHARACTERISTIC CURVE

Figure 1

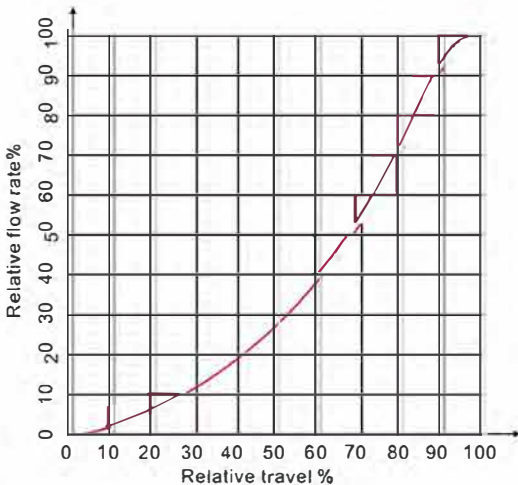

## RATED CV

Table 2

Size(mm/inch)	Rated Cv
50/2	95
65/2.5	175
80/3	270
100/4	470
125/5	850
150/6	1400
200/8	2300
250/10	3560
300/12	5800
350/14	7800
400/16	10000
450/18	13500
500/20	18000
600/24	25000
700/28	38500
800/32	48000
900/36	52500
1000/40	61700
1200/48	81000

## Cv VERSUS VALVE ROTATION, in Degrees

Table 3

Size		Cv									
mm	inch	10°	20°	30°	40°	50°	60°	70°	80°	90°	
50	2	1.53	4.29	10	12	16	20	42	82	95	
65	2 1/2	3.32	8.36	20	23	27	44	86	159	175	
80	3	4.68	14.78	27	38	39	78	152	249	270	
100	4	9.97	39.44	81	168	231	307	359	425	470	
125	5	54.06	164.04	270	391	473	531	634	781	850	
150	6	58.33	172.22	307	501	614	953	1183	1379	1400	
200	8	66.74	185.38	360	619	983	1409	1793	2171	2300	
250	10	147.95	385.90	710	1106	1646	2305	2892	3419	3560	
300	12	254.47	622.68	1078	1636	2419	3470	4435	5332	5800	
350	14	341.64	820.42	1365	2198	3234	4375	7158	7165	7800	
400	16	408.16	965.28	1654	2694	4041	5833	7634	9573	10000	
450	18	489.22	1175.31	2015	3305	4982	7238	9737	12076	13500	
500	20	692.40	1539.74	2560	4013	6321	9214	12510	15716	18000	
600	24	1027.97	2279.72	3840	5858	8934	12862	17425	22261	25000	
700	28	1274.25	2523.27	4628	7812	12254	18887	26357	33522	38500	
800	32	1811.41	4124.70	6387	10453	15803	23502	33052	42317	48000	
900	36	2463.56	4123.04	6909	11359	16879	25188	35844	44836	52500	
1000	40	4225.34	11579.49	13908	16501	21419	30477	37120	47632	61700	
1200	48	5264.63	17148.26	20640	26114	30179	37181	46032	52688	81000	

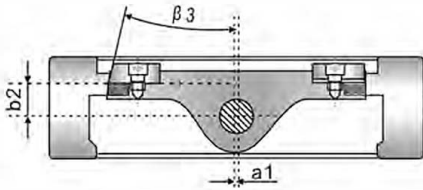

### TRIPLE OFFSET WORKING PRINCIPLE

1. Shaft centerline is offset from the centerline of the valve and of the pipe.
2. Shaft is offset behind the disc face.
3. The third offset is at the sealing face. The sealing surface on the disc is similar to a slice taken from a cone shape. This cone shape is offset from the centerline of the pipeline. The shape resulting from this third offset reduces friction and thus torque, and helps provide for uniform sealing forces around the surface of the seat.

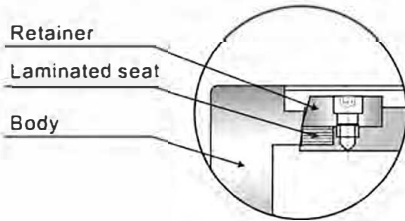

### FEATURES OF VARIOUS SEAT DESIGNS

#### Resilient Laminated Seat

1. Low operation torque and easy operation and cost saving.
2. Tight shut off up to bubble tightness.
3. Reliable tightness can be ensured even under low differential pressure.
4. Good pressure, corrosion and abrasion resistance and long circle life.

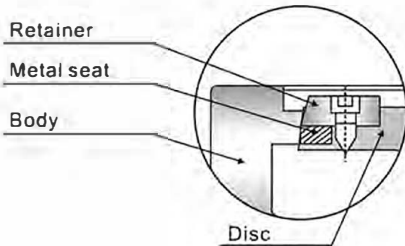

#### Metal Seat

1. Low operation torque and easy operation and cost saving.
2. Hard alloy coated metal seat provides super abrasion resistance.
3. Good pressure, corrosion and abrasion resistance and long circle life.

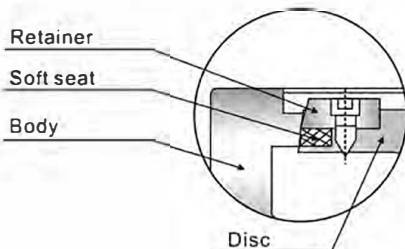

#### Soft Seat

1. Reliable bubble tightness.
2. Low operation torque and easy operation and cost saving.

## ACTUATOR SELECTION

Table 4

SIZE		Torque in N.m at 16-25bar/150-360psi DP	Z SERIES PISTON ACTUATORS		RACK&PINION(Cylinder Size mm)	
mm	inch		ZSQ Double Acting	ZDQ Spring Return	Double Acting	Spring Return
50	2	50	ZSQ41-80-14	ZDQ41-100-14	85	100
65	2 1/2	60	ZSQ41-80-14	ZDQ41-125-14	85	115
80	3	90	ZSQ41-100-16	ZDQ50-125-16	100	125
100	4	100	ZSQ41-125-20	ZDQ50-125-20	100	140
125	5	160	ZSQ50-125-20	ZDQ50-160-20	125	140
150	6	240	ZSQ50-160-25	ZDQ60-200-25	140	190
200	8	420	ZSQ60-160-30	ZDQ80-200-30	160	210
250	10	720	ZSQ60-200-35	ZDQ80-250-35	200	240
300	12	1100	ZSQ80-250-40	ZDQ100-300-40	240	300
350	14	1500	ZSQ80-250-45	ZDQ130-350-40	240	350
400	16	2500	ZSQ100-300-50	ZDQ130-400-45	270	400
450	18	4200	ZSQ130-350-50	ZDQ160-400-50	350	500
500	20	5000	ZSQ130-400-50	ZDQ160-450-60	350	500
600	24	8700	ZSQ160-450-65	/	400	600
700	28	10000	ZSQ160-450-70	/	500	600
800	32	14750	ZSQ160-500-85	/	/	/
900	36	20000	ZSQ200-500-100	/	/	/

**NOTE:**

ZSQ and ZDQ series piston actuators are manufactured by Linuo. For actuator particulars, please refer to Z Series Actuators Sizing. The actuators above are recommended for valves of pressure rating PN10/PN16/PN25/ANSI class 150 and with PTFE resilient laminated and metal seat, the minimum air supply pressure is 5 bar/72.5 psi.

For actuator sizing for higher pressure rating and temperature range, please consult factory.

Torque values excludes safety factor.

## ACTUATOR ORIENTATION

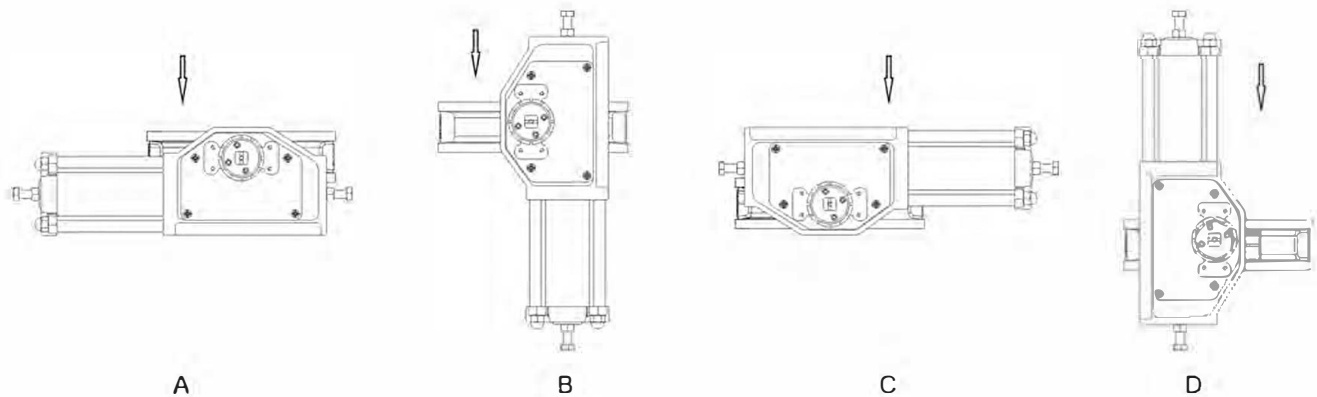

Orientation A is standard type. For requirement of other 3 orientation types, please consult factory.

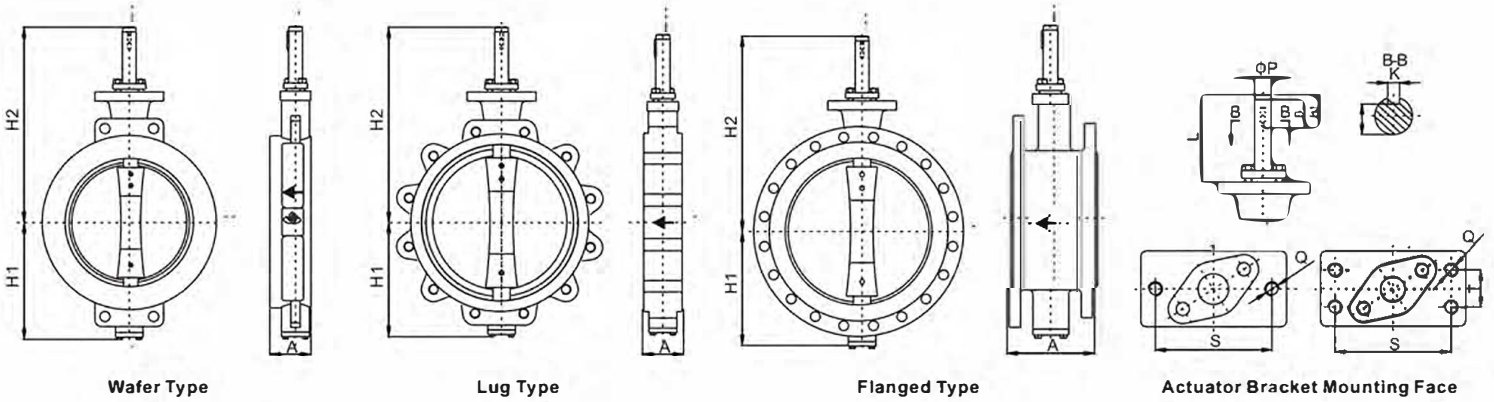

BARE SHAFT VALVES

mm/inch

Table 5

Size	A			H1	H2	L	cP	Actuator mounting dimensions						
	Wafer	Lug	Flanged					B1	B	K	N	S	Q	T
50/2"	43/1.69	43/1.69	108/4.25	104/4.09	210/8.27	109/4.29	14/0.55	28/1.10	25/0.98	5/0.20	11/0.43	65/2.56	M10	/
65/2-1/2"	49/1.93	49/1.93	112/4.41	120/4.72	230/9.06	110/4.33	14/0.55	28/1.10	25/0.98	5/0.20	11/0.43	65/2.56	M10	/
80/3"	49/1.93	49/1.93	114/4.49	122/4.80	225/8.86	110/4.33	16/0.63	28/1.10	25/0.98	5/0.20	13/0.51	80/3.15	M12	/
100/4"	56/2.20	56/2.20	127/5.00	136/5.35	240/9.45	110/4.33	20/0.79	28/1.10	25/0.98	6/0.27	16.5/0.65	80/3.15	M12	/
125/5"	64/2.52	64/2.52	140/5.51	157/6.18	268/10.55	120/4.72	20/0.79	28/1.10	25/0.98	6/0.27	16.5/0.65	90/3.54	M12	/
150/6"	70/2.76	70/2.76	140/5.51	170/6.69	280/11.02	120/4.72	25/0.98	38/1.50	35/1.38	8/0.31	21/0.83	90/3.54	M12	40/1.57
200/8"	71/2.80	71/2.80	152/5.98	200/7.87	330/12.99	140/5.51	30/1.18	43/1.69	40/1.57	10/0.39	25/0.98	110/4.33	M12	40/1.57
250/10"	76/2.99	76/2.99	165/6.50	243/9.57	380/14.96	140/5.51	35/1.38	43/1.69	40/1.57	10/0.39	30/1.18	110/4.33	M12	45/1.77
300/12"	83/3.27	83/3.27	178/7.01	268/10.55	436/17.17	160/6.30	40/1.57	54/2.13	50/1.97	12/0.47	35/1.38	130/5.12	M12	45/1.77
350/14"	92/3.62	92/3.62	190/7.48	298/11.73	485/19.09	185/7.28	45/1.77	64/2.52	60/2.36	14/0.55	39.5/1.56	134/5.28	M16	64/2.52
400/16"	102/4.02	102/4.02	216/8.50	338/13.31	524/20.63	185/7.28	50/1.97	64/2.52	60/2.36	16/0.63	44/1.73	134/5.28	M16	64/2.52
450/18"	114/4.49	114/4.49	222/8.74	367/14.45	670/26.38	225/8.86	50/1.97	65/2.56	60/2.36	16/0.63	44/1.73	175/6.89	M20	70/2.76
500/20"	127/5.00	127/5.00	229/9.02	402/15.83	658/25.91	225/8.86	50/1.97	85/3.35	80/3.15	18/0.71	53/2.09	175/6.89	M20	70/2.76
600/24"	154/6.06	154/6.06	267/10.51	470/18.50	773/30.43	245/9.65	65/2.56	85/3.35	80/3.15	18/0.71	58/2.28	215/8.46	M24	90/3.54
						225/8.86	50/1.97	70/2.76	60/2.36	16/0.63	44/1.73	180/7.09	M20	70/2.76
700/28"	165/6.50	165/6.50	292/11.50	514/20.24	818/32.20	260/10.24	70/2.76	85/3.35	80/3.15	20/0.79	62.5/2.46	215/8.46	M30	90/3.54
800/32"	190/7.48	190/7.48	318/12.52	565/22.24	905/35.63	305/12.01	70/2.76	115/4.53	110/4.33	22/0.87	76/2.99	245/9.65	M33	125/4.92
900/36"	203/7.99	203/7.99	330/12.99	637/25.08	976/38.43	300/11.81	80/3.15	85/3.35	80/3.15	22/0.87	62/2.44	260/10.24	M20	100/3.94
						325/12.80	90/3.54			25/0.98	81/3.19			
1000/40"	216/8.50	216/8.50	410/16.14	697/27.44	1038/40.87	310/12.20	105/4.13	95/3.74	90/3.54	28/1.10	95/3.74	260/10.24	M22	100/3.94
						(PN10/PN16/PN25 /150Lb. Wafer)								
1200/48"	254/10.00	254/10.00	470/18.50	804/31.65	1163/45.79	360/14.17	105/4.13	90/3.54	101/3.98	28/1.10	95/3.74	260/10.24	M22	
						325/12.80	125/4.92	106/4.17	100/3.94	32/1.26	114/4.49	310/12.20	M20	140/5.51
						(PN10/PN16/PN25 /150Lb. Flanged)								

Note: The above actuator mounting dimensions are applicable for wafer, lugged and flanged type valves of pressure rating PN10, PN16, PN25, 150Lb, unless otherwise specified.

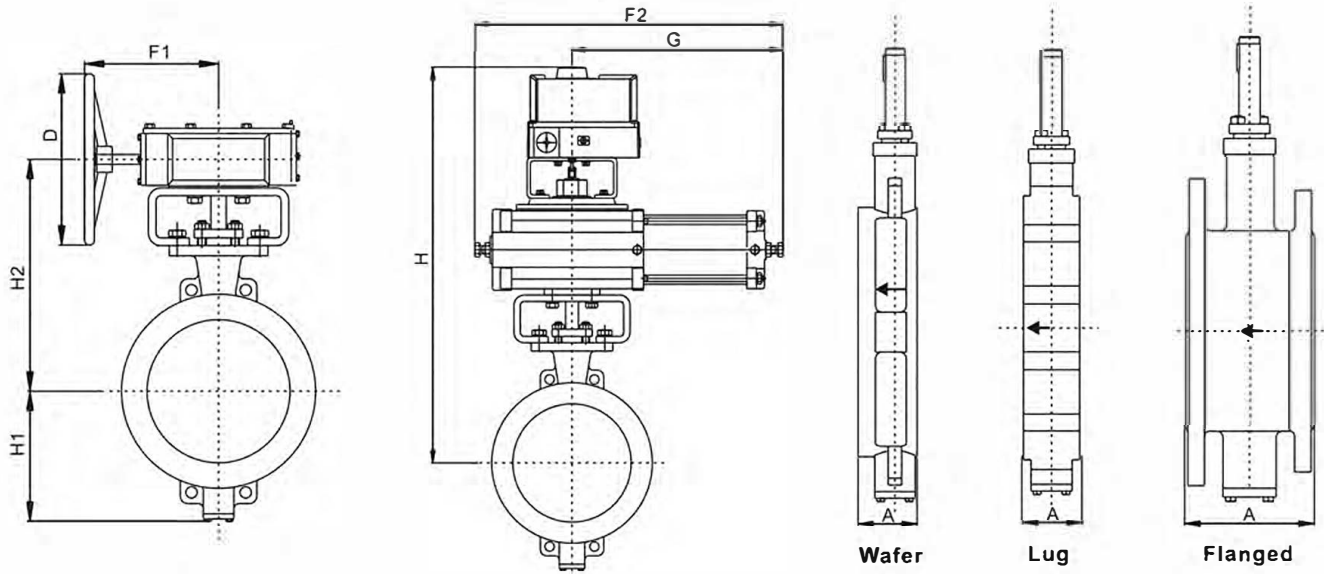

**GEARBOX AND PNEUMATIC OPERATION VALVES**

mm/inch

**Table 6**

Size	A			H1	H2	F1	cD	Double Acting			Spring Return		
	Wafer	Lug	Flanged					H	G	F2	H	G	F2
50/2"	43/1.69	43/1.69	108/4.25	104/4.09	210/8.27	110/4.33	160/6.30	470/18.50	300/11.81	422/16.61	470/18.50	480/18.90	635/25.00
65/2-1/2"	49/1.93	49/1.93	112/4.41	120/4.72	230/9.06	110/4.33	160/6.30	480/18.90	300/11.81	422/16.61	480/18.90	550/21.65	720/28.35
80/3"	49/1.93	49/1.93	114/4.49	122/4.80	225/8.86	110/4.33	160/6.30	495/19.49	315/12.40	440/17.32	505/19.89	620/24.41	770/30.31
100/4"	56/2.20	56/2.20	127/5.00	136/5.35	240/9.45	110/4.33	160/6.30	505/19.89	315/12.40	440/17.32	515/20.28	620/24.41	770/30.31
125/5"	64/2.52	64/2.52	140/5.51	157/6.18	268/10.55	167/6.57	240/9.45	560/22.05	328/12.91	474/18.66	560/22.05	660/25.98	810/31.89
150/6"	70/2.76	70/2.76	140/5.51	170/6.69	280/11.02	167/6.57	240/9.45	580/22.83	328/12.91	550/21.65	615/24.21	680/26.77	870/34.25
200/8"	71/2.80	71/2.80	152/5.98	200/7.87	330/12.99	188/7.40	280/11.02	650/25.59	356/14.02	570/22.44	710/27.95	825/32.48	950/37.40
250/10"	76/2.99	76/2.99	165/6.50	243/9.57	380/14.96	188/7.40	280/11.02	700/27.56	356/14.02	570/22.44	760/29.92	875/34.45	1170/46.06
300/12"	83/3.27	83/3.27	178/7.01	268/10.55	436/17.17	215/8.46	300/11.81	800/31.50	500/19.69	700/27.56	835/32.87	970/38.19	1260/49.61
350/14"	92/3.62	92/3.62	190/7.48	298/11.73	485/19.09	215/8.46	300/11.81	910/35.83	500/19.69	750/29.53	1000/39.37	1200/47.24	1600/62.99
400/16"	102/4.02	102/4.02	216/8.50	338/13.31	524/20.63	254/10.00	350/13.78	935/36.81	580/22.83	950/37.40	1000/39.37	1215/47.83	1615/63.58
450/18"	114/4.49	114/4.49	222/8.74	367/14.45	670/26.38	270/10.63	400/15.75	1050/41.34	750/29.53	1100/43.31	1060/41.73	1270/50.00	1660/65.35
500/20"	127/5.00	127/5.00	229/9.02	402/15.83	658/25.91	278/10.94	400/15.75	1180/46.46	870/34.25	1300/51.18	1160/45.67	1285/50.59	1680/66.14
600/24"	154/6.06	154/6.06	267/10.51	470/18.50	773/30.43	278/10.94	400/15.75	1200/47.24	870/34.25	1300/51.18	1200/47.24	1320/51.97	1900/74.80
700/28"	165/6.50	165/6.50	292/11.50	514/20.24	818/32.20	379/14.92	500/19.69	1220/48.03	870/34.25	1300/51.18	/	/	/
800/32"	190/7.48	190/7.48	318/12.52	565/22.24	905/35.63	419/16.50	500/19.69	1330/52.36	870/34.25	1300/51.18	/	/	/
900/36"	203/7.99	203/7.99	330/12.99	637/25.08	976/38.43	496/19.53	500/19.69	1390/54.72	950/37.40	1450/57.09	/	/	/
1000/40"	216/8.50	216/8.50	410/16.14	697/27.44	1038/40.87	496/19.53	500/19.69	/	/	/	/	/	/
1200/48"	254/10.00	254/10.00	470/18.50	804/31.65	1163/45.79	565/22.24	600/23.62	/	/	/	/	/	/

Note: The above dimensions are applicable for wafer, lugged and flanged type valves of PN10, PN16 and 150Lb unless otherwise specified. For actuator particulars, please refer to ACTUATOR SELECTION on Page 6

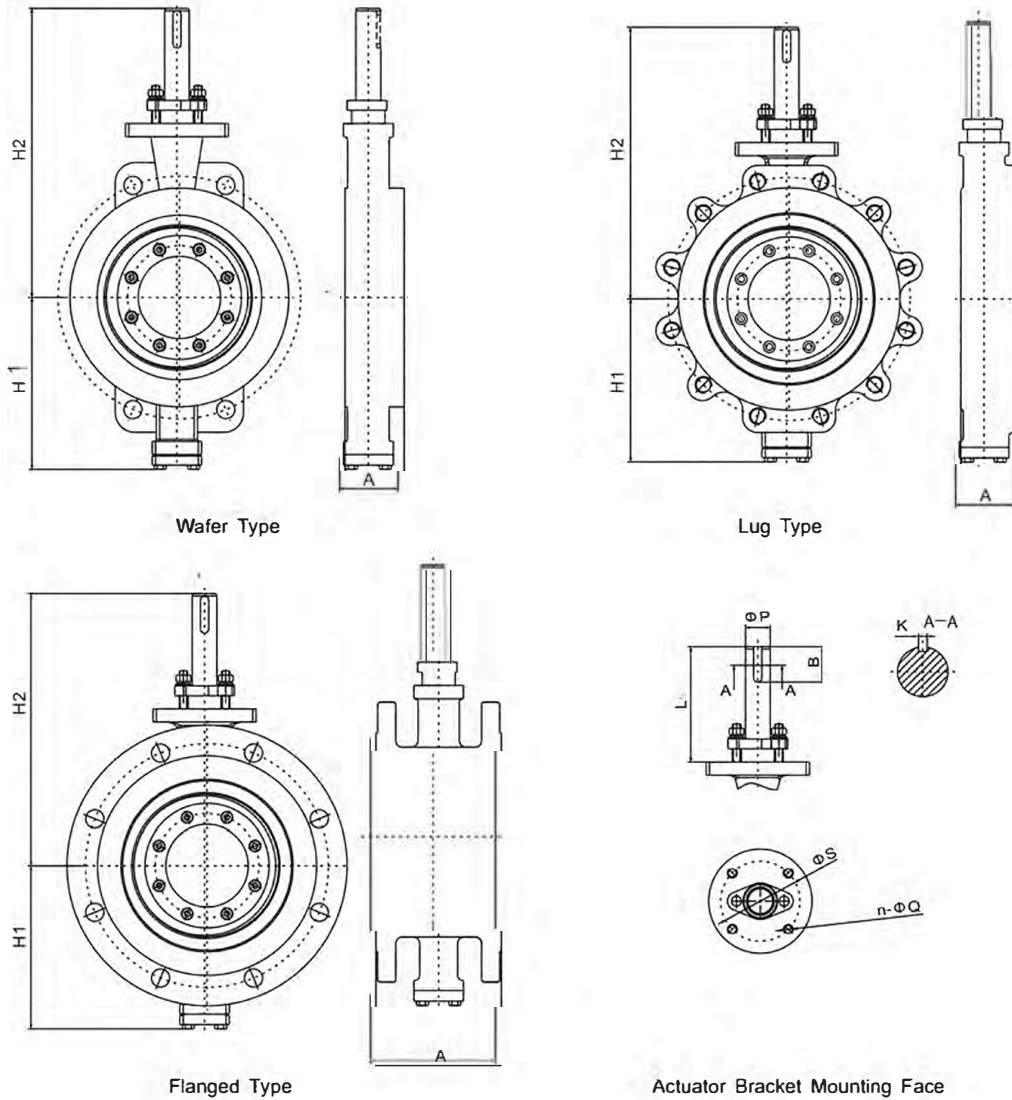

**BARE SHAFT VALVES**

mm/inch

**Table 7**

Size	A			H1	H2	Actuator mounting dimensions							
	Wafer	Lug	Flanged			L	cP	B	K	N	cS	cQ	N
50/2"	43/1.69	43/1.69	108/4.25	124.5/4.90	260/10.24	125/4.92	16/0.63	40/1.57	5/0.20	13/0.51	70/2.76	M10	4
65/2-1/2"	49/1.93	49/1.93	112/4.41	136.5/5.37	275/10.87	125/4.92	18/0.71	40/1.57	6/0.27	14.5/0.57	70/2.76	M10	4
80/3"	64/2.52	54/2.13	114/4.49	147/5.79	281/11.06	125/4.92	20/0.79	40/1.57	6/0.27	16.5/0.65	70/2.76	M10	4
100/4"	64/2.52	64/2.52	127/5.00	171/6.73	305/12.01	130/5.12	25/0.98	50/1.97	8/0.31	21/0.83	100/3.94	M12	4
125/5"	64/2.52	64/2.52	140/5.51	185/7.28	319/12.56	130/5.12	26/1.02	50/1.97	8/0.31	22/0.87	100/3.94	M12	4
150/6"	76/2.99	78/3.07	140/5.51	213/8.39	375/14.76	160/6.30	30/1.18	50/1.97	8/0.31	26/1.02	110/4.33	M14	4
200/8"	89/3.50	102/4.02	152/5.98	260/10.24	427/16.81	177/6.97	38/1.50	60/2.36	12/0.47	33/1.30	125/4.92	M16	4
250/10"	114/4.49	117/4.61	165/6.50	299/11.77	490/19.29	180/7.09	40/1.57	60/2.36	12/0.47	35/1.38	140/5.51	M16	4
300/12"	114/4.49	92/3.62	178/7.01	285/11.22	513/20.20	203/7.99	45/1.77	90/3.54	12/0.47	40.5/1.59	150/5.91	M12	4
350/14"	127/5.00	117/4.61	290/11.42	354/13.94	587/23.11	207/8.15	55/2.17	80/3.15	16/0.63	49/1.93	170/6.69	M16	8
400/16"	140/5.51	133/5.24	310/12.20	366/14.41	632/24.88	223/8.78	60/2.36	90/3.54	18/0.71	53/2.09	185/7.28	M16	4
450/18"	152/5.98	149/5.87	330/12.99	420/16.54	690/27.17	250/9.84	65/2.56	100/3.94	18/0.71	58/2.28	210/8.27	M18	8
500/20"	152/5.98	159/6.26	350/13.78	446/17.56	720/28.35	255/10.04	70/2.76	100/3.94	20/0.79	62.5/2.46	210/8.27	M18	8
600/24"	178/7.01	181/7.13	390/15.35	539/21.22	850/33.46	300/11.81	80/3.15	110/4.33	22/0.87	71/2.80	260/10.24	M22	8

Note: The above actuator mounting dimensions are applicable for wafer, lugged and flanged type valves of pressure rating PN40, 300Lb. unless otherwise specified.

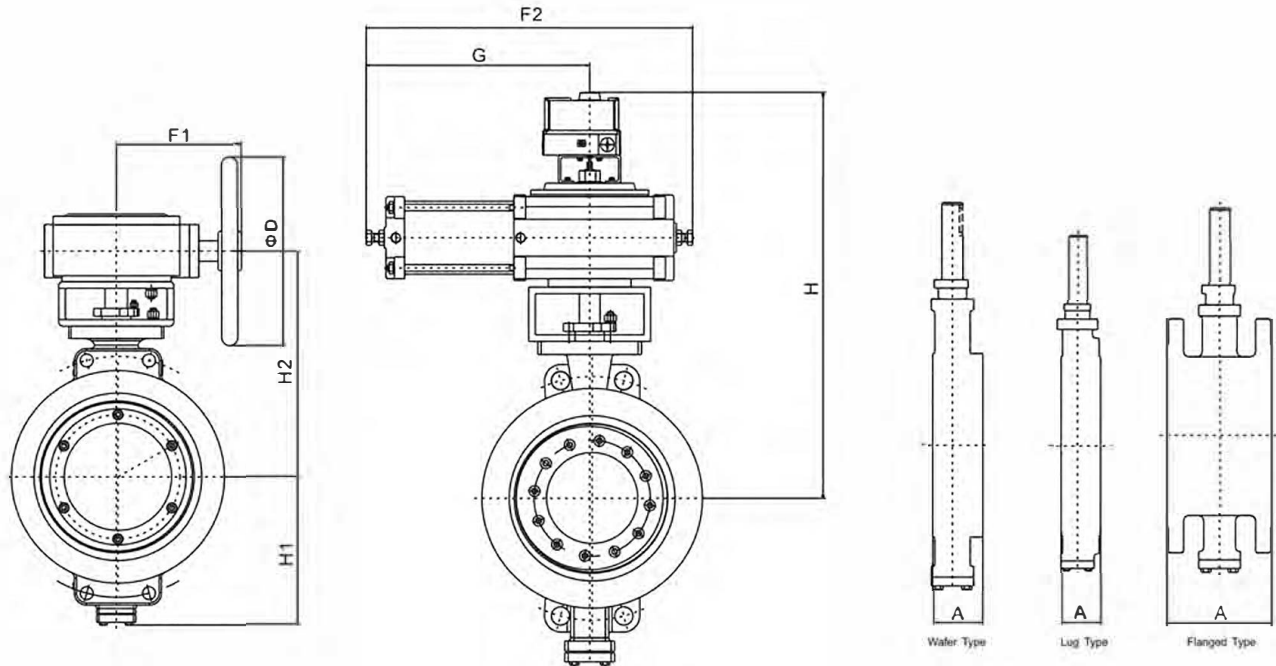
**GEARBOX AND PNEUMATIC OPERATION VALVES**

mm/inch

**Table 8**

Size	A			H1	H2	F1	cD	Double Acting			Spring Return		
	Wafer	Lug	Flanged					H	G	F2	H	G	F2
50/2"	43/1.69	43/1.69	108/4.25	124.5/4.90	235/9.25	144/5.67	200/7.87	525/20.67	305/12.01	450/17.72	525/20.67	535/21.09	695/27.36
65/2-1/2"	49/1.93	49/1.93	112/4.41	136.5/5.37	250/9.84	144/5.67	200/7.87	545/21.46	305/12.01	450/17.72	540/21.26	535/21.09	695/27.36
80/3"	64/2.52	54/2.13	114/4.49	147/5.79	260/10.24	144/5.67	200/7.87	551/21.69	305/12.01	450/17.72	578/22.76	635/25.00	795/31.30
100/4"	64/2.52	64/2.52	127/5.00	171/6.73	290/11.42	167/6.57	250/9.84	605/23.82	370/14.57	530/20.87	640/25.20	635/25.00	835/32.87
125/5"	64/2.52	64/2.52	140/5.51	185/7.28	305/12.01	167/6.57	250/9.84	659/25.94	400/15.75	580/22.83	719/28.31	825/32.48	1070/42.13
150/6"	76/2.99	78/3.07	140/5.51	213/8.39	355/13.98	188/7.40	280/11.02	705/27.76	400/15.75	580/22.83	765/30.12	825/32.48	1070/42.13
200/8"	89/3.50	102/4.02	152/5.98	260/10.24	405/15.94	215/8.46	320/12.60	829/32.64	535/21.09	780/30.71	810/31.89	825/32.48	1070/42.13
250/10"	114/4.49	117/4.61	165/6.50	299/11.77	465/18.31	246/9.69	320/12.60	916/36.06	535/21.09	780/30.71	924/36.38	940/37.01	1220/48.03
300/12"	114/4.49	92/3.62	178/7.01	285/11.22	470/18.50	324/12.76	350/13.78	911/35.87	590/23.23	870/34.25	1015/39.96	1160/45.67	1500/59.06
350/14"	127/5.00	117/4.61	290/11.42	354/13.94	560/22.05	324/12.76	350/13.78	1000/39.37	750/29.53	1090/42.91	1066/41.97	1160/45.67	1500/59.06
400/16"	140/5.51	133/5.24	310/12.20	366/14.41	575/22.64	348/13.70	350/13.78	1151/45.31	750/29.53	1090/42.91	1131/44.53	1240/48.82	1670/65.75
450/18"	152/5.98	149/5.87	330/12.99	420/16.54	640/25.20	392/15.43	400/15.75	1155/45.47	800/31.50	1230/48.43	/	/	/
500/20"	152/5.98	159/6.26	350/13.78	446/17.56	675/26.57	415/16.34	400/15.75	1180/46.46	800/31.50	1230/48.43	/	/	/
600/24"	178/7.01	181/7.13	390/15.35	539/21.22	685/26.97	496/19.53	520/20.47	1305/51.38	870/34.25	1300/51.18	/	/	/

Note: The above dimensions are applicable for wafer, lugged and flanged, type valves of PN40 and 300Lb unless otherwise specified.  
 For actuator particulars, please refer to ACTUATOR SELECTION on Page 6

# HOW TO ORDER



### 1 Valve Type

BW	Butterfly Valve
----	-----------------

### 2 Size

050	DN50	2"	300	DN300	12"	900	DN900	36"
065	DN65	2-1/2"	350	DN350	14"	1000	DN1000	40"
080	DN80	3"	400	DN400	16"	1200	DN1200	48"
100	DN100	4"	450	DN450	18"			
125	DN125	5"	500	DN500	20"			
150	DN150	6"	600	DN600	24"			
200	DN200	8"	700	DN700	28"			
250	DN250	10"	800	DN800	32"			

### 3 Connection Type

F1 Flanged (RF)	D1 Wafer (RF)	L1 Lug
-----------------	---------------	--------

### 4 Pressure Rating

10	PN10	01	150Lb	1K	10K
16	PN16	03	300Lb	2K	20K
25	PN25	06	600Lb	3K	30K
40	PN40	09	900Lb	4K	40K
64	PN64	15	1500Lb	/	/

### 5 Body Material

C	WCB	G	CG8M
P	CF8	B	LCB
Q	CF3	D	LCC
M	CF8M	W	WC6
L	CF3M	S	Duplex SS

### 6 Disc Material and Body Sealing Face Material

Disc material		Body Sealing Face Material	
1	WCB	0	Integral with body
3	CF8	D	13%Cr surfacing
4	CF3	B	6AB surfacing
5	CF8M	3	Nickel based alloy surfacing
6	CF3M	4	Tungsten carbide alloy surfacing
7	CG8M	6	Stellite surfacing
S	Duplex SS		

### 7 Sealing Type

Laminated or Metal seat	Y
Soft seat	R

### 8 Seat Material and Disc Sealing Face Material

Seat Material	Metal seat		Soft seat Material
	Disc Sealing Face Material		
1	A105	0	Integral with seat material
2	F6a	D	13%Cr surfacing
3	304	B	6AB surfacing
4	304L	3	Nickel based alloy surfacing
5	316	4	Tungsten Carbide alloy surfacing
6	316L	6	Stellite surfacing
7	317	7	Graphite layers
S	2205		

### 9 O-ring Material

Material and temperature	
W	Without O-ring

### 10 Actuator

ZS	Pneumatic double acting
ZDK	Pneumatic spring return to close
ZDB	Pneumatic spring return to open
ZK	Electric
SD	Manual operation

Wide industrial application range served by KV Controls product including  
Chemical / Petrochemical / Oil & Gas / Pulp & Paper / Biochemistry / Pharmaceutical / Water /  
Mining