

Ball Valve

F/M MINI BALL VALVE

FEATURES

- ◆ 1000PSI/PN63
- ◆ Reduce Port
- ◆ Investment Casting
- ◆ Blow-out proof Stem
- ◆ External polished
- ◆ Max temperature: -25°C to 180°C
- ◆ PTFE seats & seals
- ◆ Thread: ASME B1.20.1 BS21.DIN2999/259, ISO228-1, JIS B 0203, ISO7/1
- ◆ Inspection Testing: API598, EN12266

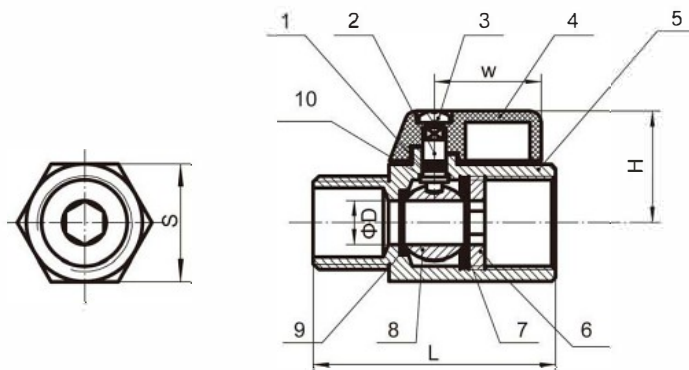

MATERIALS LIST

ITEM	DESIGNATION	QTY	MATERIAL
1	O-RING	2	VITON
2	STEM	1	304/316
3	BOLT	1	304
4	LEVER	1	ALUMINUM ALLOY
5	BODY	1	CF8/CF8M
6	CAP	1	CF8/CF8M
7	BALL SEAT(A)	1	PTFE
8	BALL	1	304/316
9	BALL SEAT(B)	1	PTFE
10	THRUST WASHER	1	PTFE

DIMENSIONS(mm)

ITEM	SIZE	1/4"	3/8"	1/2"	3/4"	1"
D		8	8	9.2	12.5	15
L		39	41	46	55	65
H		26.5	26.5	28.3	31.5	34
W		22.8	22.8	22.8	22.8	22.8
S		21	21	24.5	31	38

Note: If the thread is taper type(NPT/BSPT),the nominal diameter is 7MM.

Ball Valve

F/F MINI BALL VALVE

FEATURES

- ◆ 1000PSI/PN63
- ◆ Reduce Port
- ◆ Investment Casting
- ◆ Blow-out proof Stem
- ◆ External polished
- ◆ Max temperature: -25°C to 180°C
- ◆ PTFE seats & seals
- ◆ Thread: ASME B1.20.1 BS21.DIN2999/259, ISO228-1, JIS B 0203, ISO7/1
- ◆ Inspection Testing: API598, EN12266

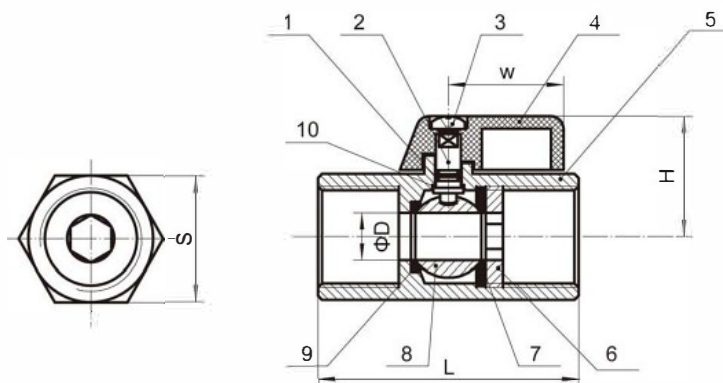

MATERIALS LIST

ITEM	DESIGNATION	QTY	MATERIAL
1	O-RING	2	VITON
2	STEM	1	304/316
3	BOLT	1	304
4	LEVER	1	ALUMINUM ALLOY
5	BODY	1	CF8/CF8M
6	CAP	1	CF8/CF8M
7	BALL SEAT(A)	1	PTFE
8	BALL	1	304/316
9	BALL SEAT(B)	1	PTFE
10	THRUST WASHER	1	PTFE

DIMENSIONS(mm)

ITEM \ SIZE	1/4"	3/8"	1/2"	3/4"	1"
D	8	8	9.2	12.5	15
L	39	41	46	55	65
H	26.5	26.5	28.3	31.5	34
W	22.8	22.8	22.8	22.8	22.8
S	21	21	24.5	31	38

Note: If the thread is taper type(NPT/BSPT),the nominal diameter is 7MM.

Ball Valve

1PC BALL VALVE (QF101)



FEATURES

- ◆ 1000PSI/PN63
- ◆ Reduce Port
- ◆ Investment Casting
- ◆ Blow-out proof Stem
- ◆ Casting Approved AD2000-W0
- ◆ PED97/23/EC(CE0035)Approved
- ◆ W.P: 1/4"-2" 1000psi 2 1/2"-4" 800psi
- ◆ Thread: ASME B1.20.1 BS21.DIN2999/259, ISO228-1, JIS B 0203, ISO7/1
- ◆ Inspection Testing: API598, EN12266

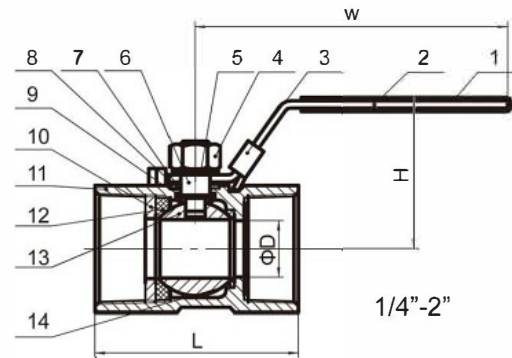
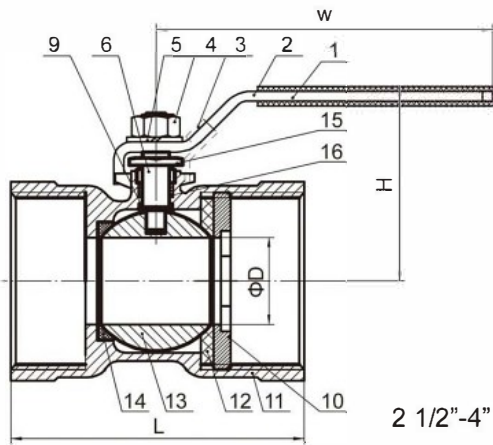

ITEM	DESIGNATION	MATERIAL
1	HANDLE SLEEVE	PVC
2	HANDLE	304
3	LOCKING	304
4	STEM NUT	304
5	SPRING WASHER	304
6	STEM	304/316
7	PACKING RING	304
8	STEM PACKING	PTFE
9	THRUST WASHER	PTFE
10	CAP	CF8/CF8M
11	BODY	CF8/CF8M
12	BALL SEAT	RPTFE
13	BALL	304/316
14	BALL SEAT	PTFE
15	GLAND NUT	304
16	STEM PACKING	PTFE

SIZE	ΦD	L	H	W	S	
1/4"	5	39	31	65	17	HEX
3/8"	6.8	44	36	85	21	
1/2"	9.2	56.5	41	95	25	
3/4"	12.5	59	44	95	32	
1"	15	71	48	111	38	
1-1/4"	20	78	54	111	49	
1-1/2"	25	83	65	135	53	
2"	32	100	72	135	65	OCT
2-1/2"	38	120	80	154	83	
3"	50	140	100	191	98	
4"	64	170	129	246	127	

Ball Valve

1PC HEXAGON BAR STOCK 2000 PSI BALL VALVE (QF102)

FEATURES

- ◆ WInternal Blow-out Proof Stem
- ◆ Pressure Rating: 2000 PSI (PN125)
- ◆ Thread Ends: ANSI B2.1, BS 21, DIN2999/259
- ◆ Material: Carbon Steel
- ◆ Pressure Test: API 598



DIMENSIONS(mm)

SIZE	Φ D	L	H	W	SW	
1/4"	5	43	35	73	20	HEX
3/8"	7	45	38	73	25	
1/2"	9.5	62	50	115	30	
3/4"	12.5	70	58	115	36	
1"	15	85.5	62	129	41(46)	
1-1/4"	20	94	64	129	53	
1-1/2"	25	101.5	72	150	60	
2"	32	114	80	150	70(75)	

MATERIALS LIST

ITEM	DESIGNATION	QTY	MATERIAL
1	PLASTIC COVER	1	PLASTIC
2	HANDLE	1	304
3	STEM NUT	2	304
4	STEM	1	304
5	PACK RING	1	304
6	STEM PACKING	1	PTFE
7	THRUST WASHER	1	PTFE
8	BODY	1	CARBON STEEL
9	BODY GASKET	1	PTFE
10	CAP	1	WCB
11	BALL SEAT	2	PTFE/RPTFE
12	BALL	1	304

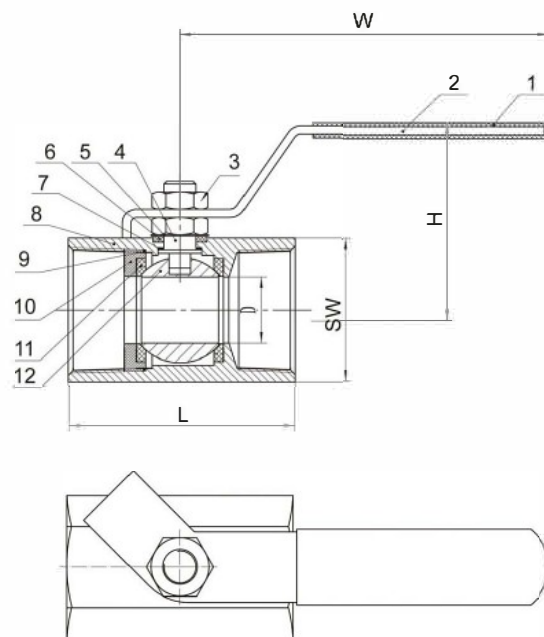
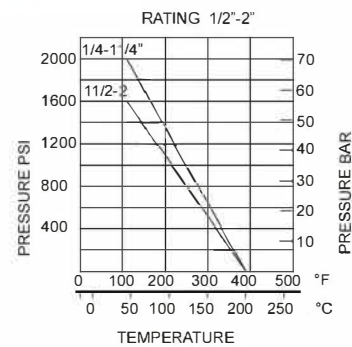

Ball Valve

1PC 2000 PSI CASTING BALL VALVE (QF103)

FEATURES

- ◆ 2000PSI(PN150)
- ◆ Reduce Port
- ◆ Investment Casting
- ◆ Blow-out proof Stem
- ◆ Tapped & drilled mounting pad (option)
- ◆ PED97/23/PE (CE0035) Approved
- ◆ Casting Approved AD2000W0
- ◆ Thread: ASME B1.20.1 BS21.DIN999/259, ISO228-1, JIS B 0203, ISO7/1
- ◆ Inspection Testing: API598, EN12266

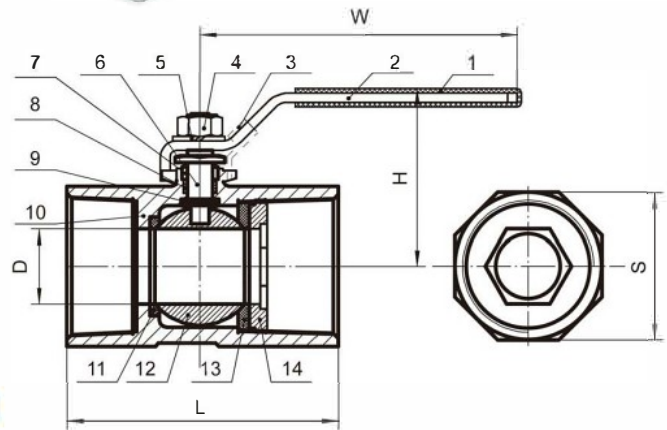
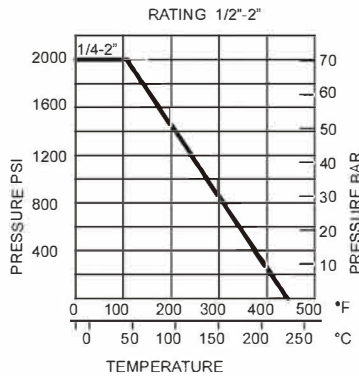

MATERIALS LIST

ITEM	DESIGNATION	MATERIAL
1	HANDLE SLEEVE	PVC
2	HANDLE	304
3	LOCKING	304
4	STEM NUT	304
5	SPRING WASHER	304
6	STEM	304/316
7	PACK RING	304
8	STEM PACKING	PTFE
9	THRUST WASHER	PTFE
10	BODY	CF8/CF8M
11	SEAT(A)	RPTFE
12	BALL	CF8/CF8M
13	SEAT(B)	RPTFE
14	INSERT	304/316

DIMENSIONS(mm)

SIZE	ΦD	L	H	W	S
1/4	9.2	59	44	91	22
3/8	9.2	59	44	91	22
1/2	9.2	67	44	91	26
3/4	12.5	71	47.5	111	32
1	15	84	60	111	40
1 1/4	20	94	65	126	50
1 1/2	25	100	71	126	55
2	32	114	76.5	154	70

Ball Valve

2PC REDUCE PORT BALL VALVE 800 PSI (QF201)

FEATURES

- ◆ 800PSI(PN40)
- ◆ Reduce Port
- ◆ Investment Casting
- ◆ Blow-out proof Stem
- ◆ PED97/23/PE (CE0035) Approved
- ◆ Casting Approved AD2000-W0
- ◆ Thread: ASME B1.20.1 BS21.DIN2999/259, ISO228-1, JIS B 0203, ISO7/1
- ◆ Inspection Testing: API598, EN12266

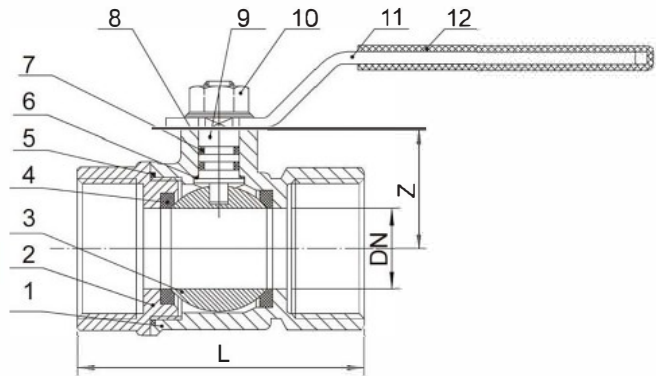
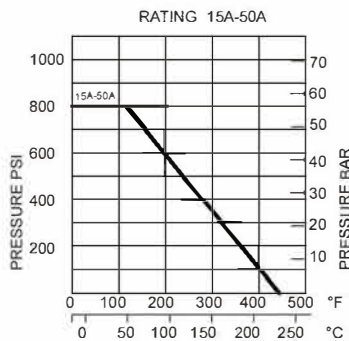

ITEM	DESIGNATION	QTY	MATERIAL
1	BODY	1	CF8/CF8M
2	CAP	1	CF8/CF8M
3	BALL	1	CF8/CF8M
4	BALL SEAT	2	RPTFE
5	JOINT GASKET	1	PTFE
6	THRUST WASHER	1	PTFE
7	O-RING	2	NBR
8	STEM PACKING	1	PTFE
9	STEM	1	304/316
10	NUT	1	304
11	HANDLE	2	304
12	HANDLE SLEEVE	1	PVC

ITEM	15A	20A	25A	32A	40A	50A
L	48.5	58.5	69	79	89	100.5
DN	10	15	20	25	31	39
S	25	30	38	47	53	65
Z	21	23.5	31	33	41	47

Ball Valve

2PC REDUCE PORT BALL VALVE 1000 PSI (QF202)

FEATURES

- ◆ 1000PSI/PN63
- ◆ Reduce Port
- ◆ Investment Casting
- ◆ Blow-out proof Stem
- ◆ PED97/23/PE (CE0035) Approved
- ◆ Casting Approved AD200 0-W0
- ◆ Thread: ASME B1.20.1 BS21.DIN2999/259,
ISO228-1, JIS B 0203, ISO7/1
- ◆ Inspection Testing: API598, EN12266

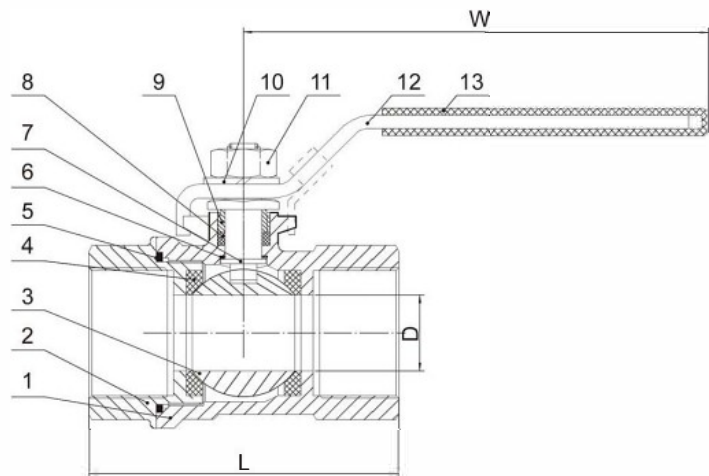
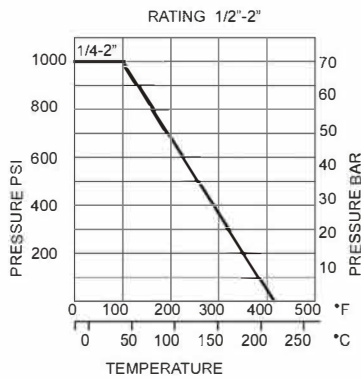

ITEM	DESIGNATION	QTY	MATERIAL
1	BODY	1	CF8/CF8M
2	CAP	1	CF8/CF8M
3	BALL	1	CF8/CF8M
4	BALL SEAT	2	RPTFE
5	JOINT GASKET	1	PTFE
6	THRUST WASHER	1	PTFE
7	STEM	1	304/316
8	STEM PACKING	1	PTFE
9	GLAND NUT	1	304
10	SPRING WASHER	1	304
11	STEM NUT	1	304
12	HANDLE	1	304
13	HANDLE SLEEVE	1	PVC

SIZE	D	L	W	S
3/8"	9.2	38.5	76	21
1/2"	10	48.5	91	25
3/4"	15	58.5	91	30
1"	20	69	111	38
1 1/4"	25	79	111	47
1 1/2"	32	90	154	53
2"	38	100	154	66

Ball Valve

2PC LIGHT-DUTY BALL VALVE (QF203)

FEATURES

- ◆ 1000PSI/PN63
- ◆ Full Port
- ◆ Blow-out-proof stem design
- ◆ PED97/23/PE (CE0035) Approved
- ◆ Casting Approved AD2000-W0
- ◆ Thread: ASME B1.20.1 BS21.DIN2999/259, ISO228-1, JIS B 0203, ISO7/1
- ◆ Inspection Testing: API598, EN12266

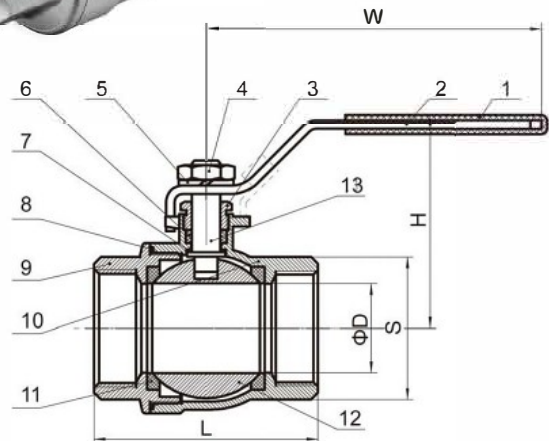
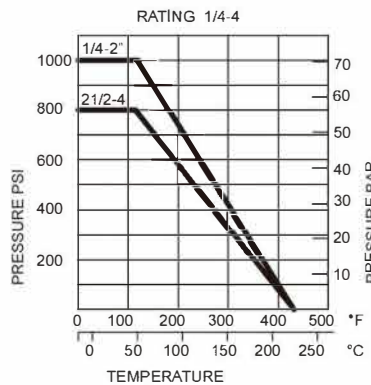

ITEM	DESIGNATION	QTY	MATERIAL
1	HANDLE SLEEVE	1	PVC
2	HANDLE	1	304
3	GLAND NUT	1	304
4	STEM NUT	1	304
5	SPRING WASHER	1	304
6	STEM PACKING	1	PTFE
7	THRUST WASHER	1	PTFE
8	JOINT GASKET	1	PTFE
9	CAP	1	CF8/CF8M
10	BODY	1	CF8/CF8M
11	BALL SEAT	2	RPTFE
12	BALL	1	CF8/CF8M
13	STEM	1	304/316

SIZE	D	L	H	W	S
1/4"	9.2	36	41	76	18
3/8"	12.5	42	46	76	21
1/2"	15	48	50	85	25
3/4"	20	58	57	95	31
1"	25	68.5	68	120	37.5
1-1/4"	32	80	74	120	46.5
1-1/2"	38	90.5	85	150	53
2"	50	109	94	150	66
2 1/2"	65	139	120	215	82.5
3"	80	157	130	215	97.5
4"	100	200	160	300	127

Ball Valve

2PC ECONOMICAL TYPE BALL VALVE (QF204)

FEATURES

- ◆ 1000PSI/PN63
- ◆ Full Port
- ◆ Blow-out-proof stem design
- ◆ PED97/23/PE (CE0035) Approved
- ◆ Casting Approved AD2000-W0
- ◆ Thread: ASME B1.20.1 BS21.DIN2999/259, ISO228-1, JIS B 0203, ISO7/1
- ◆ Inspection Testing: API598, EN12266

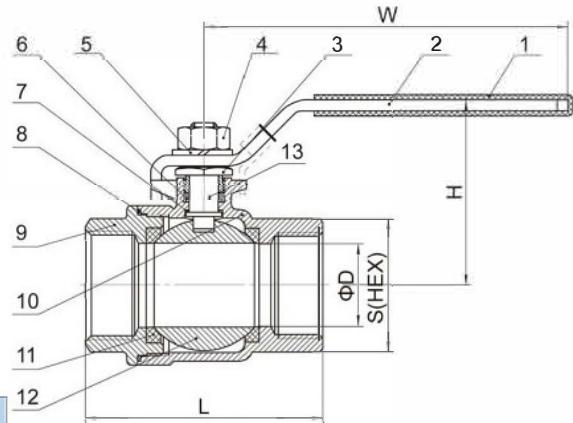
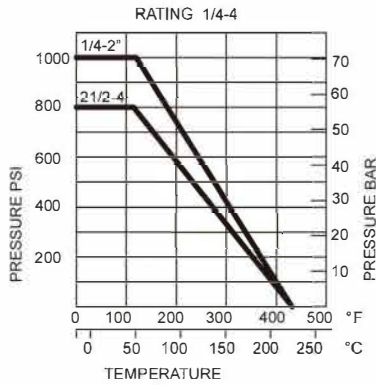

ITEM	DESIGNATION	QTY	MATERIAL
1	HANDLE SLEEVE	1	PVC
2	HANDLE	1	304
3	GLAND NUT	1	304
4	STEM NUT	1	304
5	SPRING WASHER	1	304
6	STEM PACKING	1	PTFE
7	THRUST WASHER	1	PTFE
8	JOINT GASKET	1	PTFE
9	CAP	1	CF8/CF8M
10	BODY	1	CF8/CF8M
11	BALL SEAT	2	RPTFE
12	BALL	1	CF8/CF8M
13	STEM	1	304/316

SIZE	D	L	H	W	S
1/4"	11.6	48.5	48	91	19
3/8"	12.5	48.5	48	91	21
1/2"	15	58	52	103	25.5
3/4"	20	65	61	111	31
1"	25	77	65	126	37.5
1-1/4"	32	90	79	154	46.5
1-1/2"	38	98	83	154	53.5
2"	50	121	97	192	66
2-1/2"	64	145	129	246	82.5
3"	76	166	138	246	97.5
4"	94	240	175	317	130

Ball Valve

2PC HEAVY TYPE BALL VALVE (QF205)

FEATURES

- ◆ 1000PSI/PN63
- ◆ Full Port
- ◆ Blow-out-proof stem design
- ◆ Body and end caps quality investment casting
- ◆ PED97/23/PE (CE0035) Approved
- ◆ Casting Approved AD2000-W0
- ◆ Thread: ASME B1.20.1 BS21.DIN999/259, ISO228-1, JIS B 0203, ISO7/1
- ◆ Inspection Testing: API598, EN12266

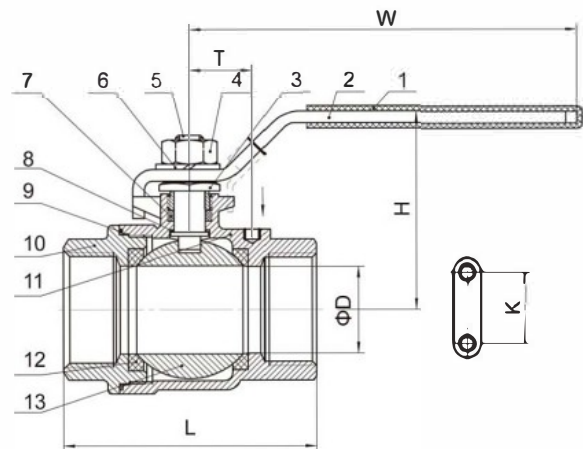
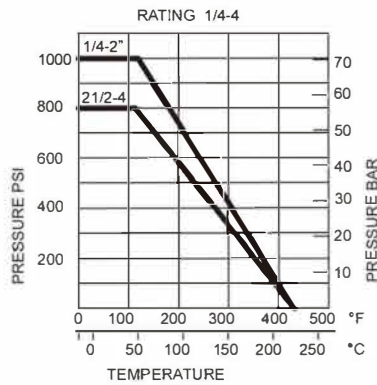

ITEM	DESIGNATION	QTY	MATERIAL
1	HANDLE SLEEVE	1	PVC
2	HANDLE	1	304
3	GLAND NUT	1	304
4	STEM NUT	1	304
5	STEM	1	304/316
6	SPRING WASHER	1	304
7	STEM PACKING	1	PTFE
8	THRUST WASHER	1	PTFE
9	JOINT GASKET	1	PTFE
10	CAP	1	CF8/CF8M
11	BODY	1	CF8/CF8M
12	BALL SEAT	2	RPTFE
13	BALL	1	CF8/CF8M

SIZE	D	L	H	W	K	T
1/4"	11.6	50	48	91	28.5	12.5
3/8"	12.5	50	48	91	28.5	12.5
1/2"	15	58	52	103	28.5	13
3/4"	20	65	61	111	34.8	21
1"	25	80	65	126	34.8	22.5
1-1/4"	32	92	79	154	38.1	23.5
1-1/2"	38	105	83	154	38.1	23.5
2"	50	125	97	191	38.1	23.5
2-1/2"	64	155.6	129	244	56	32
3"	76	183	138	244	56	35
4"	94	240	175	315	63	50

Ball Valve

2PC DIN3202-M3 BALL VALVE (QF206)

FEATURES

- ◆ 1000PSI/PN63
- ◆ Full Port
- ◆ Investment Casting
- ◆ Blow-out proof Stem
- ◆ PED97/23/PE (CE0035) Approved
- ◆ Casting Approved AD2000W0
- ◆ Length confirm to DIN3202/4-M3
- ◆ Thread: ASME B1.20.1 BS21.DIN2999/259, ISO228-1, JIS B 0203, ISO7/1
- ◆ Inspection Testing: API598, EN12266

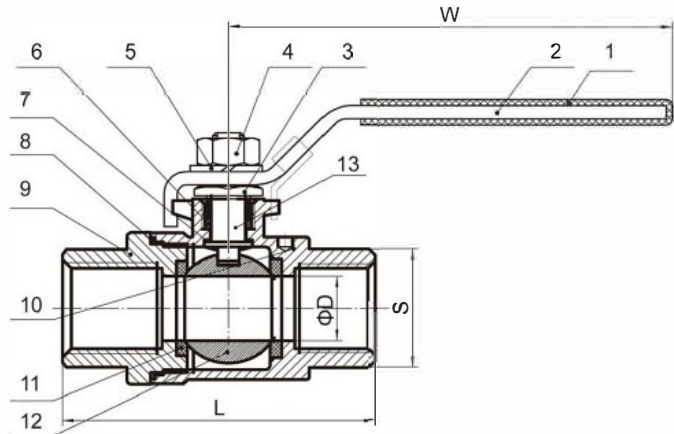
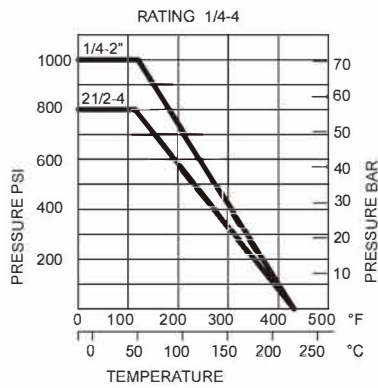

ITEM	DESIGNATION	MATERIAL
1	HANDLE SLEEVE	PVC
2	HANDLE	304
3	GLAND NUT	304/316
4	STEM NUT	304
5	SPRING WASHER	304
6	STEM PACKING	PTFE
7	THRUST WASHER	PTFE
8	JOINING GASKET	PTFE
9	CAP	CF8/CF8M
10	BODY	CF8/CF8M
11	BALL SEAT	RPTFE
12	BALL	CF8/CF8M
13	STEM	304/316

SIZE	D	L	H	W	S
1/4"	11.5	55	48	103	22
3/8"	12.5	60	48	103	22
1/2"	15	75	52	103	26
3/4"	20	80	61	123	32
1"	25	90	65	123	39
1-1/4"	32	110	79	153	48.5
1-1/2"	38	120	83	153	55
2"	50	140	97	185	68
2-1/2"	64	185	135	243	84
3"	76	205	144	243	99
4"	94	240	166	295	128

2PC BALL VALVE 2000 PSI (QF207)

FEATURES

- ◆ Full port
- ◆ W.P.: 1/4"-2" 2000WOG(PN150)
- ◆ Investment casting Blow-out proof stem
- ◆ Anti-static device & locking device(option)
- ◆ ASME B16.34 Wall thickness NACE MR0175
- ◆ Thread type: ASME B1.20.1 BS21.DIN2999/259, ISO228-1, JIS B 0203, ISO7/1
- ◆ Inspection Testing: API598, EN12266

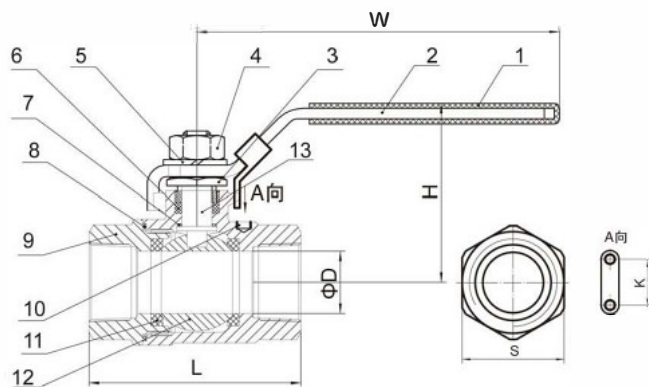
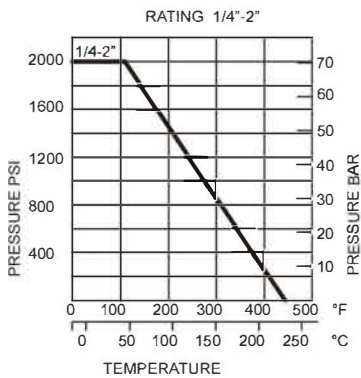

ITEM	DESIGNATION	MATERIAL
1	HANDLE SLEEVE	PVC
2	HANDLE	304
3	GLAND NUT	304/316
4	STEM NUT	304
5	SPRING WASHER	304
6	STEM PACKING	PTFE
7	THRUST WASHER	PTFE
8	JOINT GASKET	PTFE
9	CAP	CF8/CF8M
10	BODY	CF8/CF8M
11	BALL SEAT	RPTFE
12	BALL	CF8/CF8M
13	STEM	304/316

SIZE	D	L	H	W	k	S
1/4"	9.2	54.3	48	91	28.5	25
3/8"	9.2	54.3	48	91	28.5	25
1/2"	12.7	61	52	103	28.5	30
3/4"	20	70	61	111	34.8	36
1"	25	82	65	126	34.8	44.6
1-1/4"	32	91.5	79	154	38.1	54
1-1/2"	38	113	83	154	38.1	61
2"	50	124	97	191	38.1	75

Ball Valve

2PC BALL VALVE M/F (QF209)

FEATURES

- ◆ 1000PSI/PN63
- ◆ Full Port
- ◆ Investment Casting
- ◆ Blow-out proof Stem
- ◆ Locking Device Handle (Option)
- ◆ PED97/23/PE (CE0035) Approved
- ◆ Casting Approved AD2000-W0
- ◆ Thread: ASME B1.20.1 BS21.DIN2999/259, ISO228-1, JIS B 0203, ISO7/1
- ◆ Inspection Testing: API598, EN12266

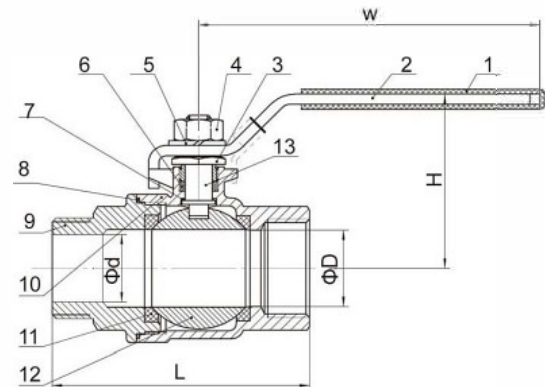
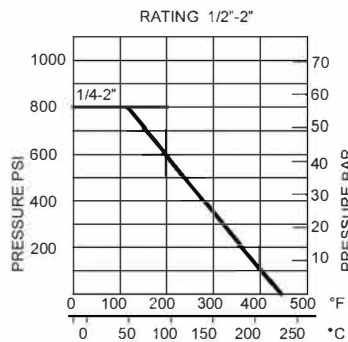

ITEM	DESIGNATION	QTY	MATERIAL
1	HANDLE SLEEVE	1	PVC
2	HANDLE	1	304
3	GLAND NUT	1	304
4	STEM NUT	1	304
5	SPRING WASHER	1	304
6	STEM PACKING	1	PTFE
7	THRUST WASHER	1	PTFE
8	JOINT GASKET	1	PTFE
9	CAP	1	CF8/CF8M
10	BODY	1	CF8/CF8M
11	BALL SEAT	2	RPTFE
12	BALL	1	CF8/CF8M
13	STEM	1	304/316

SIZE	D	d	L	H	W	S
1/4"	11.6	8	55	48	91	19
3/8"	12.5	11.4	55	48	91	21
1/2"	15	13.6	71.5	52	91	25.5
3/4"	20	18.2	78	61	111	31
1"	25	23	91	65	111	37.5
1-1/4"	32	32	100	79	154	46.5
1-1/2"	38	38	112	83	154	53.5
2"	50	48	142	97	192	66

Ball Valve

2PC BALL VALVE WITH ISO5211 MOUNTING PAD(QF203M)

FEATURES

- ◆ Full port 1000PSI(PN63)
- ◆ Investment Casting
- ◆ Blow-out proof Stem
- ◆ ISO5211 Mounting Pad
- ◆ PED97/23/PE (CE0035) Approved
- ◆ Anti-Static device(option)
- ◆ Thread: ASME B1.20.1 BS21.DIN2999/259, ISO228-1, JIS B 0203, ISO7/1
- ◆ Inspection Testing: API598, EN12266

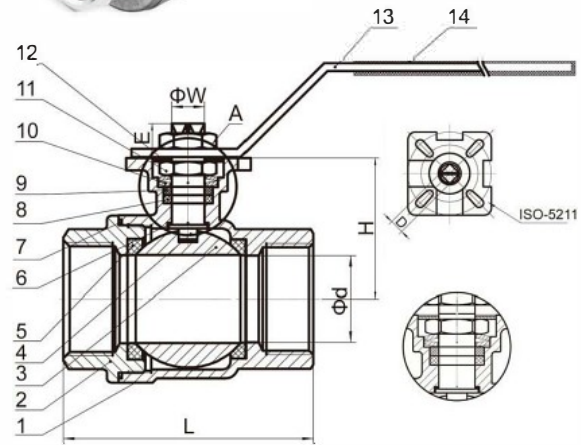
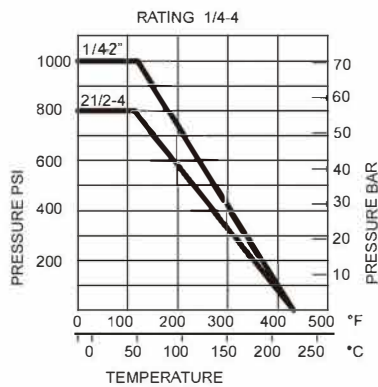

ITEM	DESIGNATION	MATERIAL
1	BODY	CF8/CF8M
2	CAP	CF8/CF8M
3	BALL	CF8/CF8M
4	STEM	304/316
5	BALL SEAT	RPTFE
6	THRUST WASHER	PTFE
7	JOINT GASKET	PTFE
8	STEM PACKING	PTFE
9	GLAND RING	304
10	SPRING WASHER	304
11	STEM NUT	304
12	AGAINST PINE PAD	304
13	HANDLE	304
14	HANDLE SLEEVE	PVC

SIZE	Φd	L	H	D	E	W	ISO5211
1/4"	11.6	49	36.5	9	9	12	F04/03
3/8"	12.5	49	36.5	9	9	12	F04/03
1/2"	15	58	37.8	9	9	12	F04/03
3/4"	20	65	42.5	9	9	12	F04/03
1"	25	77	45	11	11	14	F05/04
1-1/4"	32	90	51.5	11	11	14	F05/04
1-1/2"	38	98	59.5	14	14	18	F07/05
2"	50	121	68.5	14	14	18	F07/05
2-1/2"	64	156	98.5	17	16	22	F10/07
3"	76	186	108	17	16	22	F10/07

Ball Valve

3PC BALL VALVE (QF301)

FEATURES

- ◆ 1000PSI/PN63
- ◆ Full Port
- ◆ Investment Casting
- ◆ Blow-out proof Stem
- ◆ Locking Device Handle(Optional)
- ◆ PED97/23/PE (CE0035) Approved
- ◆ Anti-Static device(option)
- ◆ Thread: ASME B1.20.1 BS21.DIN2999/259, ISO228-1, JIS B 0203, ISO7/1
- ◆ Inspection Testing: API598, EN12266

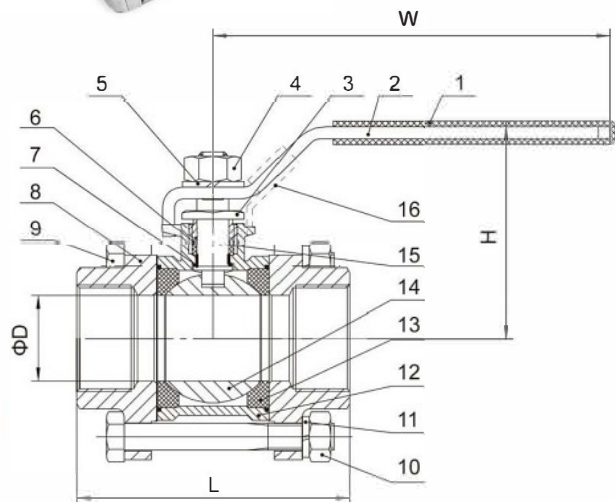
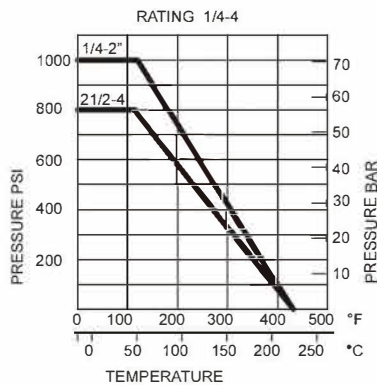

ITEM	DESIGNATION	QTY	MATERIAL
1	HANDLE SLEEVE	1	PVC
2	HANDLE	1	304
3	GLAND NUT	1	304/316
4	STEM NUT	1	304
5	STEM WASHER	1	304
6	STEM PACKING	1	PTFE
7	THRUST WASHER	1	PTFE
8	END CAP	2	CF8/CF8M
9	BOLT	4(6)	304
10	NUT	4(6)	304
11	SPRING WASHER	4(6)	304
12	BODY	1	CF8/CF8M
13	BALL SEAT	2	RPTFE
14	BALL	1	CF8/CF8M
15	STEM	1	304/316
16	LOCKING DEVICE	1	304

SIZE	D	L	H	W
1/4"	11	50	48	103
3/8"	12	50	48	103
1/2"	15	60	52	103
3/4"	20	70	61	123
1"	25	80	65	123
1-1/4"	32	93	79	153
1-1/2"	38	100	83	153
2"	50	125	97	185
2-1/2"	64	158	135	243
3"	76	179	144	243
4"	94	223	172	315

Ball Valve

3PC BUTT WELD BALL VALVE (QF302)

FEATURES

- ◆ 1000PSI/PN63
- ◆ Full Port
- ◆ Investment Casting
- ◆ Blow-out proof Stem
- ◆ PED97/23/PE (CE0035) Approved
- ◆ Casting Approved AD2000-W0
- ◆ Anti-Static device(option)
- ◆ Butt Weld: ASME B16.25 (SCH40)
- ◆ Inspection Testing: API598, EN12266

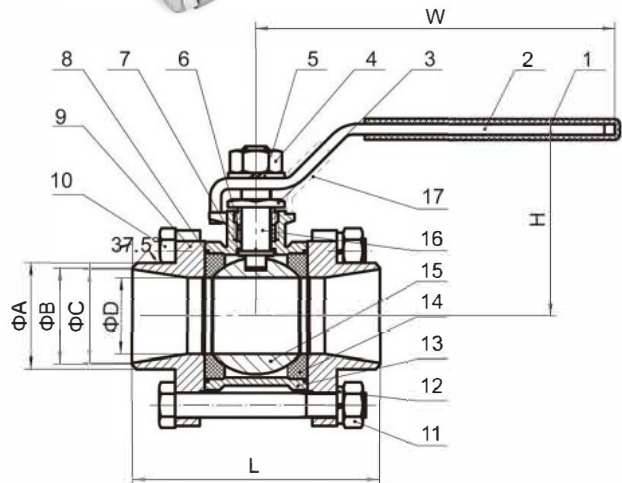
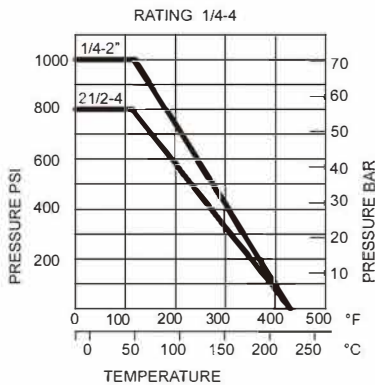

ITEM	DESIGNATION	QTY	MATERIAL
1	HANDLE SLEEVE	1	PVC
2	HANDLE	1	304
3	GLAND NUT	1	304
4	STEM NUT	1	304
5	SPRING WASHER	1	304
6	STEM PACKING	1	PTFE
7	THRUST WASHER	1	PTFE
8	JOINT GASKER	2	PTFE
9	CAP	2	CF8/CF8M
10	BOLT	4(6)	304
11	BOLT NUT	4(6)	304
12	SPRING WASHER	4(6)	304
13	BODY	1	CF8/CF8M
14	BALL SEAT	2	RPTFE
15	BALL	1	CF8/CF8M
16	STEM	1	304/316
17	LOCKING DEVICE	1	304

SIZE	ΦA	ΦB	ΦC	ΦD	L	H	W
1/4"	18	14.5	10.8	10.8	60.4	48	103
3/8"	19.5	15.9	11	11	60.4	48	103
1/2"	23	19.2	15	15	66.5	52	103
3/4"	28.8	23.4	21	20	80	61	123
1"	34.8	28.6	26.7	25	84	65	123
1-1/4"	45	38	34	32	104	79	153
1-1/2"	51	44	40.5	38	112	83	153
2"	62.5	56.5	52.5	50	132	97	185
2-1/2"	77	68	65	64	164	135	243
3"	94	86	80.5	76	182.2	144	243
4"	116	105	98	94	226.8	172	315

Ball Valve

3PC SOCKET WELD BALL VALVE (QF303)

FEATURES

- ◆ 1000PSI/PN63
- ◆ Full Port
- ◆ Investment Casting
- ◆ Blow-out proof Stem
- ◆ PED97/23/PE (CE0035) Approved
- ◆ Casting Approved AD2000-W0
- ◆ Anti-Static device(option)
- ◆ Socket Weld: ASME B16.11
- ◆ Inspection Testing: API598, EN12266

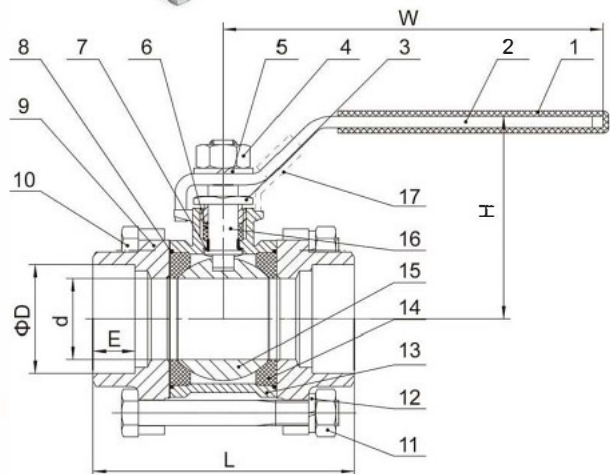
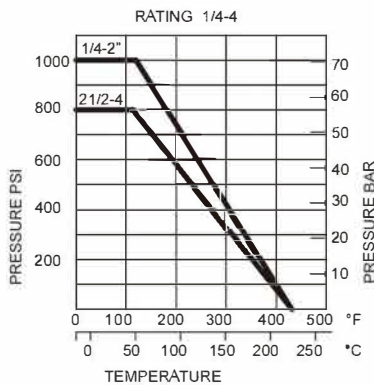

ITEM	DESIGNATION	QTY	MATERIAL
1	HANDLE SLEEVE	1	PVC
2	HANDLE	1	304
3	GLAND NUT	1	304
4	STEM NUT	1	304
5	STEM WASHER	1	304
6	STEM PACKING	1	PTFE
7	THRUST WASHER	1	PTFE
8	JOINT GASKET	2	PTFE
9	END CAP	2	CF8/CF8M
10	BOLT	4(6)	304
11	NUT	4(6)	304
12	SPRING WASHER	4(6)	304
13	BODY	1	CF8/CF8M
14	BALL SEAT	2	RPTFE
15	BALL	1	CF8/CF8M
16	STEM	1	304/316
17	LOCKING DEVICE	1	304

SIZE	d	D	E	L	H	W
1/4"	12	14.2	10	50	48	103
3/8"	12	17.6	10	50	48	103
1/2"	15	21.7	10	60	52	103
3/4"	20	27.1	13	70	61	123
1"	25	33.9	13	80	65	123
1-1/4"	32	42.6	13	93	79	153
1-1/2"	38	48.7	13	100	83	153
2"	50	61.1	16	125	97	185
2-1/2"	64	77	16	158	135	243
3"	76	89.8	16	179	144	243
4"	94	115.5	19	223	172	315

Ball Valve

3PC DIN3202-M3 LENGTH BALL VALVE (QF304)

FEATURES

- ◆ 1000PSI/PN63
- ◆ Full Port
- ◆ Investment Casting
- ◆ Blow-out proof Stem
- ◆ PED97/23/PE (CE0035) Approved
- ◆ Casting Approved AD2000-W0
- ◆ Anti-Static device(option)
- ◆ Length Conform To DIN3202/4-M3
- ◆ Thread: ASME B1.20.1 BS21.DIN2999/259, ISO228-1, JIS B 0203, ISO7/1
- ◆ Inspection Testing: API598, EN12266

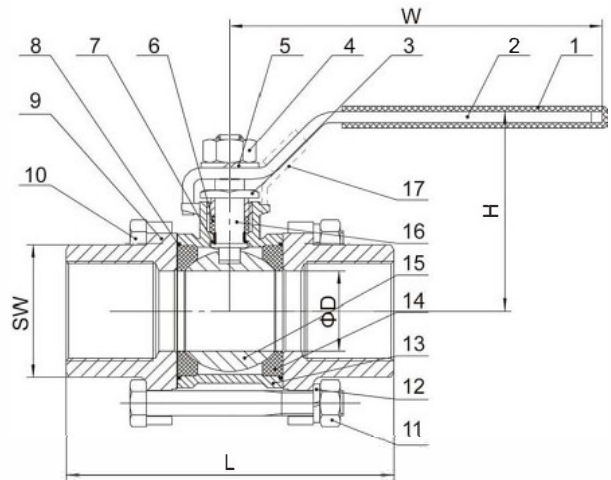
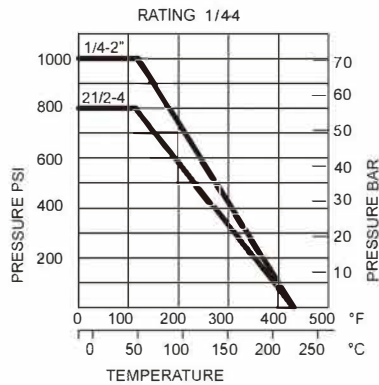

ITEM	DESIGNATION	QTY	MATERIAL
1	HANDLE SLEEVE	1	PVC
2	HANDLE	1	304
3	GLAND NUT	1	304
4	STEM NUT	1	304
5	STEM WASHER	1	304
6	STEM PACKING	1	PTFE
7	THRUST WASHER	1	PTFE
8	GASKET	2	PTFE
9	END CAP	2	CF8/CF8M
10	BOLT	1	304
11	NUT	4	304
12	SPRING WASHER	4	304
13	BODY	1	CF8/CF8M
14	BALL SEAT	2	RPTFE
15	BALL	1	CF8/CF8M
16	STEM	1	304/316
17	LOCKING DEVICE	1	304

SIZE	D	L	H	W	SW
1/4"	11.6	55	64	103	19
3/8"	12.7	60	64	103	21
1/2"	15	75	64	103	26
3/4"	20	80	73	103	31
1"	25	90	89.2	135	38
1-1/4"	32	110	94.5	135	47
1-1/2"	38	120	119.5	182	54
2"	50	140	128.5	182	66
2-1/2"	64	185	140	260	84
3"	76	205	147	260	99
4"	94	240	172	400	128

Ball Valve

3PC

BALL VALVE WITH ISO5211 MOUNTING PAD(QF302M)



FEATURES

- ◆ 1000PSI/PN63
- ◆ Full Port
- ◆ Investment Casting
- ◆ Blow-out proof Stem
- ◆ ISO5211 Mounting Pad
- ◆ PED97/23/PE (CE0035) Approved
- ◆ Anti-Static device(option)
- ◆ Thread: ASME B1.20.1 BS21.DIN2999/259, ISO228-1, JIS B 0203, ISO7/1
- ◆ Inspection Testing: API598, EN12266

ITEM	DESIGNATION	QTY	MATERIAL
1	BODY	1	CF8/CF8M
2	CAP	2	CF8/CF8M
3	BALL	1	CF8/CF8M
4	BALL SEAT	2	RPTFE
5	STEM	1	304/316
6	THRUST WASHER	1	PTFE
7	SPRING WASHER	4	304
8	BOLT NUT	4	304
9	STEM PACKING	1	PTFE
10	RING	1	304
11	BELLEVILLE WASHER	2	301
12	LOCK WASHER	1	304
13	STOP PIN	1	304
14	HANDLE NUT	2	304
15	HANDLE	1	304
16	HANDLE SLEEVE	1	PVC
17	WASHER	1	CF8/CF8M
18	O-RING	1	VITON
19	BOLT	4	304

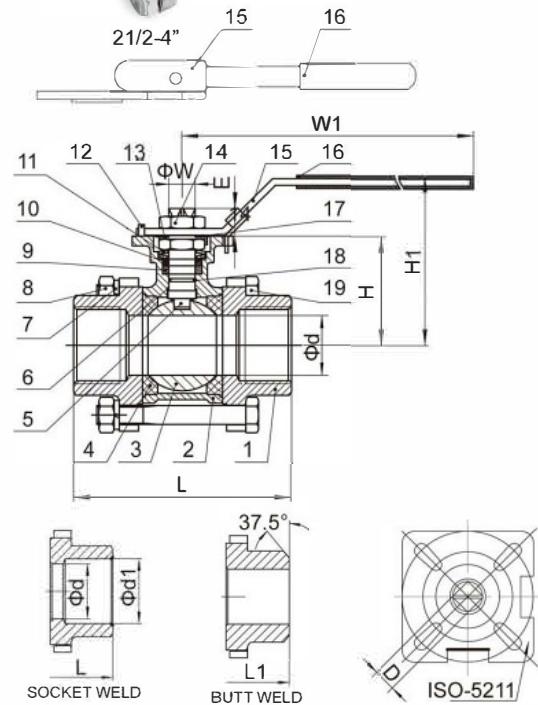

SIZE	$\Phi d \pm 0.5$	$\Phi d1 \pm 0.5$	$L \pm 2$	$L1 \pm 2$	$H \pm 1$	$D_{-0.07}^0$	$E \pm 1$	$W_{-0.3}^0$	ISO5211	W1	H1
1/4"	11.6	14.2	55	70	38	9	9	12	F04/03	143	65
3/8"	12.5	17.7	60	70	38	9	9	12	F04/03	143	65
1/2"	15	21.8	75	70	38	9	9	12	F04/03	143	65
3/4"	20	27.2	80	85	47	9	9	12	F04/03	143	76
1"	25	34	90	95	60	11	11	14	F05/04	160	95
1-1/4"	32	42.7	110	110	62.7	11	11	14	F05/04	160	95
1-1/2"	38	48.8	120	120	79	14	14	18	F07/05	187	115
2"	50	61.2	140	142	88	14	14	18	F07/05	187	124
2-1/2"	64	74	185	185	109	17	17	22	F10/07	350	140
3"	76	90	205	205	116	17	17	22	F10/07	350	150
4"	94	115.6	240	240	142	22	22	28	F12/07	350	175

Ball Valve

3PC REDUCED 3000PSI BALL VALVE (QF306)

FEATURES

- ◆ 3000PSI
- ◆ Reduce Port
- ◆ Investment Casting
- ◆ Blow-out proof Stem
- ◆ PED97/23/PE (CE0035) Approved
- ◆ Casting Approved AD2000-W0
- ◆ Anti-Static device(option)
- ◆ Thread: ASME B1.20.1 BS21.DIN2999/259, ISO228-1, JIS B 0203, ISO7/1
- ◆ Inspection Testing: API598, EN12266

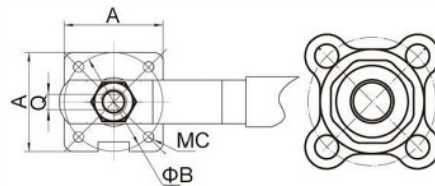
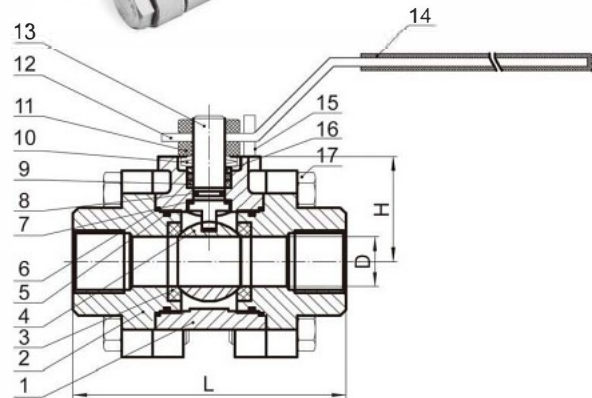
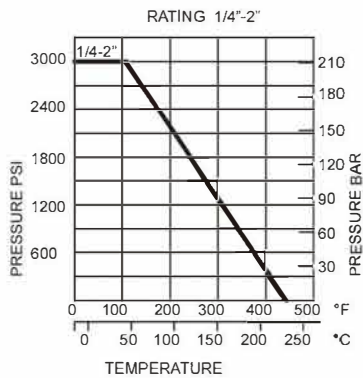

ITEM	DESIGNATION	QTY	MATERIAL
1	BODY	1	CF8/CF8M
2	END CAP	2	CF8/CF8M
3	BALL SEAT	2	RPTFE
4	BALL	1	CF8/CF8M
5	O-RING	2	VITON
6	JOINT GASKET	2	PTFE
7	THRUST WASHER	2	PTFE
8	O-RING	2	VITON
9	STEM PACKING	2	PTFE
10	BELLEVILLE WASHER	2	301
11	STEM NUT	2	304
12	HANDLE	1	304
13	STEM	1	304/316
14	HANDLE SLEEVE	1	PVC
15	STOP PIN	1	304
16	RING	1	304
17	BOLT	1	304

SIZE	ΦD	L	H	W	A	B	MC	Q
1/4"	11	92.6	31.5	140	36	36	6	9
3/8"	12.5	92.6	31.5	140	36	36	6	9
1/2"	12.5	92.6	31.5	140	36	36	6	9
3/4"	15	89.6	37	140	36	36	6	9
1"	20	112.8	46.5	160	42	42	6	11
1-1/4"	25	125	53	160	42	42	6	11
1-1/2"	32	165	65	185	70	50	8	14
2"	38	165	82	185	70	50	8	14

Ball Valve

1PC WAFER BALL VALVE (QF101F)



FEATURES

- ◆ PN16/PN40
- ◆ Full Port
- ◆ Investment Casting
- ◆ Blow-out proof Stem
- ◆ PED97/23/PE (CE0035) Approved
- ◆ Casting Approved AD2000-W0
- ◆ Anti-Static device(option)
- ◆ Design: EN12516
- ◆ End Flange: DIN2542-DIN2545
- ◆ Inspection Testing: API598, EN12266

ITEM	DESIGNATION	QTY	MATERIAL
1	HANDLE SLEEVE	1	PVC
2	HANDLE	1	304
3	STOP BLOCK	1	304
4	STEM NUT	2	304
5	SPRING WASHER	2	304
6	STEM RING	1	304
7	STEM PACKING	2	PTFE
8	STEM	1	304/316
9	THRUST WASHER	1	PTFE
10	CAP	1	CF8/CF8M
11	BALL	1	CF8/CF8M
12	BALL SEAT	2	RPTFE
13	JOINT GASKET	1	PTFE
14	BODY	1	CF8/CF8M

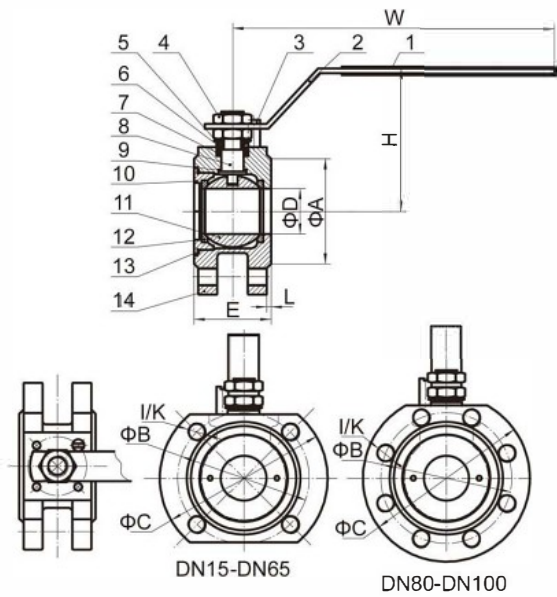

SIZE	ΦA	ΦB	ΦC	ΦD	E	H	W	L	I/K	ISO5211	pressure class
DN15	45	65	90	15	37	70	120	2	4-M12	F03	PN40
DN20	58	75	105	20	40	73	120	2	4-M12	F03	
DN25	68	85	115	25	43	78	165	2	4-M12	F04	
DN32	78	100	140	32	51	85	165	3	4-M16	F04	
DN40	88	110	150	38	63	92	200	3	4-M16	F05	
DN50	102	125	165	50	81	100	200	3	4-M16	F05	
DN65	122	145	185	64	101	140	240	3	4-M16	F07	PN16
DN80	138	160	200	80	118	150	240	3	8-M16	F07	
DN100	158	180	220	97	150	170	265	3	8-M16	F10	

Ball Valve

1PC WAFER FLANGED BALL VALVE WITH ISO5211 MOUNTING PAD (QF101M)

FEATURES

- ◆ PN16 ◆ Full Port
- ◆ Investment Casting ◆ Blow-out proof Stem
- ◆ ISO5211 Mounting Pad
- ◆ Locking Device Handle(Optional)
- ◆ PED97/23/PE (CE0035) Approved
- ◆ Anti-Static device(option) ◆ Design: EN12516
- ◆ End Flange: DIN2542-DIN2545
- ◆ Inspection Testing: API598, EN12266



ITEM	DESIGNATION	MATERIAL
1	BODY	CF8/CF8M
2	CAP	CF8/CF8M
3	BALL	CF8/CF8M
4	SEAL	RPTFE
5	STEM	304
6	STEM PACKING	PTFE
7	O-RING	NBR
8	STEM SEAT	PTFE
9	GLAND	304
10	SPRING WASHER	301
11	NUT	304
12	WASHER	304
13	HANDLE SLEEVE	PVC
14	HANDLE	304
15	LOCKING	304
16	BOLT	304
17	BOLT NUT	304
18	BOLT WASHER	304
19	BODY PACKING	PTFE

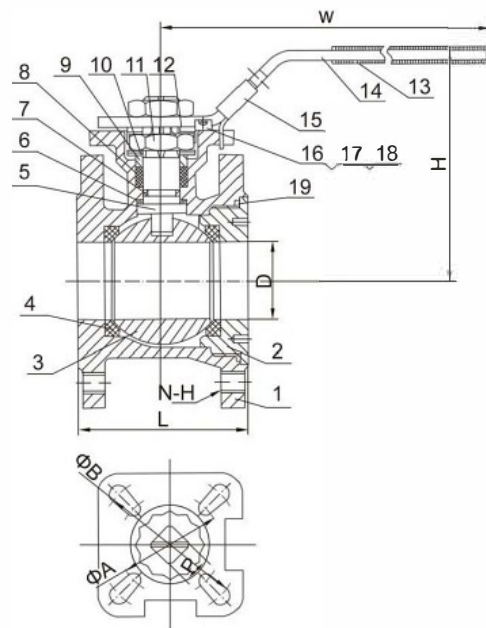

SIZE	D	P	A	B	N-H	W	H	L	ISO5211
DN15	15	9	36	42	4-M12	140	78	42	F04/03
DN20	20	9	36	42	4-M12	140	84	44	F04/03
DN25	25	11	42	50	4-M12	152	93	50	F04/03
DN32	32	11	42	50	4-M16	152	105	60	F04/03
DN40	38	14	50	70	4-M16	188	112	65	F05/04
DN50	50	14	50	70	4-M16	188	120	80	F05/04
DN65	65	17	70	102	4-M16	230	145	113	F07/05
DN80	76	17	70	102	8-M16	230	155	120	F07/05
DN100	94	22	102	102	8-M16	230	189	154	F10

Ball Valve

2PC

ANSI FLANGED BALL VALVE WITH DIRECT MOUNTING PAD (QF201M)

FEATURES

- ◆ ANSI CLASS150
- ◆ Full Port
- ◆ Investment Casting
- ◆ Blow-out proof Stem
- ◆ ISO5211 Mounting Pad
- ◆ PED97/23/PE (CE0035) Approved
- ◆ Anti-Static device(option)
- ◆ Design: ASME B16.34
- ◆ End Flange:ASME B16.5
- ◆ Inspection Testing: API598



ITEM	DESIGNATION	MATERIAL
1	BODY	CF8/CF8M
2	CAP	CF8/CF8M
3	BALL	CF8/CF8M
4	BALL SEAT	RPTFE
5	STEM	304/316
6	THRUST WASHER	PTFE
7	O-RING	NBR
8	V-RING PACKING	PTFE
9	GLAND	304
10	BELIEVLE WASHER	301
11	NUT	304
12	WASHER	304
13	HANDLE	304
14	STOP BOLT	304
15	NUT	304
16	WASHER	304
17	HANDLE	304
18	HANDLE SLEEVE	PVC
19	LOCKING	304
20	BODY GASKET	PTFE
21	NUT	304
22	BOLT	304
23	TRIANGLE STOPPER	304
24	HANDLE ADAPTER	304
25	SET SCREWED	304
26	HANDLE	304
27	HANDLE SLEEVE	PVC

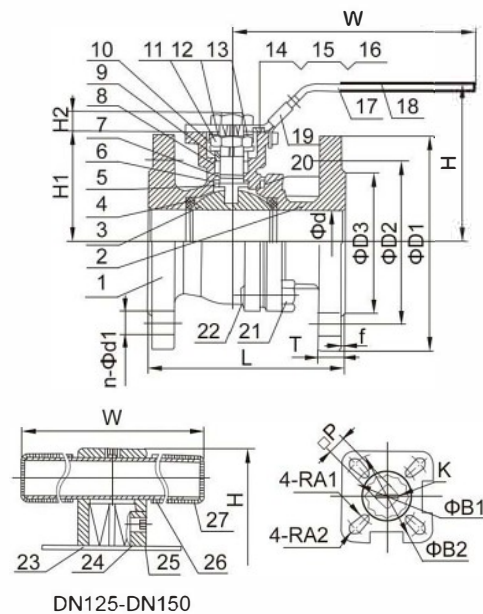

SIZE	Φd	L	T	f	D1	D2	D3	n	Φd1	H1	H2	H	W	K	P	A1	A2	B1	B2
1/2"	15	108	9.7	1.6	89	60.5	35	4	16	48.3	8	80	140	M12×1.5	9	3	3	36	42
3/4"	20	117	10.5	1.6	98.6	70	43	4	16	53	8	85	140	M12×1.5	9	3	3	36	42
1"	25	127	11.2	1.6	108	79.2	51	4	16	58.5	11	95	160	M14×1.5	11	3	3.5	42	50
1 1/4"	32	140	12.7	1.6	117	88.9	63.5	4	16	71	11	108	160	M14×1.5	11	3	3.5	42	50
1 1/2"	38	165	14.7	2	125	98.4	73.2	4	16	76	14	114	185	M18×1.5	14	3.5	4.5	50	70
2"	50	178	16.3	2	150	120.7	92	4	19	84.5	14	124	185	M18×1.5	14	3.5	4.5	50	70
2 1/2"	65	190	17.9	2	180	139.7	104.7	4	19	101.5	17	148	230	M22×1.5	17	4.5	5.5	70	102
3"	76	203	19.5	2	190	152.4	127	4	19	111.5	17	158	230	M22×1.5	17	4.5	5.5	70	102
4"	100	229	24.3	2	230	190.5	157.2	8	19	141	22	191	230	M28×2	22	M10		102	
5"	120	356	24	2	254	216	186	8	22.4	160	40.5	242	500	M36×2	27	M12		125	
6"	150	394	25.4	2	279.4	241.3	216	8	22.4	184	40.5	270	800	M36×2	27	M12		125	

Ball Valve

2PC DIN FLANGED BALL VALVE (QF203F)

FEATURES

- ◆ DIN PN16-40
- ◆ Full Port
- ◆ Investment Casting
- ◆ Blow-out proof Stem
- ◆ Locking Device Handle(Optional)
- ◆ PED97/23/PE (CE0035) Approved
- ◆ Anti-Static device(option)
- ◆ Design: DIN3357, EN12516
- ◆ End Flange: DIN2501, PN10-40
- ◆ Face to Face: DIN3202-F4
- ◆ Inspection Testing: DIN3230/3, EN12266



ITEM	DESIGNATION	QTY	MATERIAL
1	BODY	1	1.4408/1.4308
2	CAP	1	1.4408/1.4308
3	BALL	1	1.4408/1.4308
4	BALL SEAT	2	RPTFE
5	STEM	1	304/316
6	BODY GASKET	1	PTFE
7	STEM PACKING	1	PTFE
8	V-RING PACKING	1	PTFE
9	GLAND	1	304
10	NUT	2	304
11	STOP PIN	1	304
12	HANDLE	1	304
13	HANDLE SLEEVE	1	PVC
14	NUT	4-8	304
15	BOLT	4-8	304

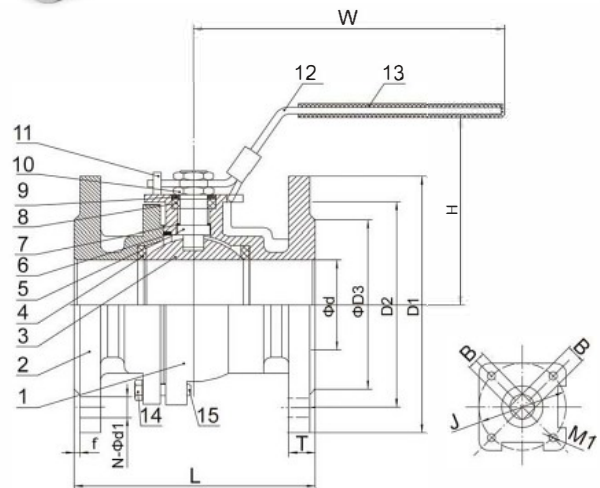

SIZE	d	B	H	W	L	D3	D2	D1	T	f	d1	N	J	M1	BOLT NUMBER	
1/2"	15	11	80	160	115	45	65	95	16	2	14	4	42	M5	4	PN16 PN40
3/4"	20	11	90	160	120	58	75	105	18	2	14	4	42	M5	4	
1"	25	14	95	160	125	68	85	115	18	2	14	4	50	M6	4	
1-1/4"	32	14	105	160	130	78	100	140	18	2	18	4	50	M6	4	
1-1/2"	38	17	110	220	140	88	110	150	18	3	18	4	70	M8	4	
2"	50	17	118	220	150	102	125	165	18	3	18	4	70	M8	4	PN16
2-1/2"	65	17	136	220	170	122	145	185	18	3	18	8	70	M8	6	
3"	76	22	158	320	180	138	160	200	20	3	18	8	102	M10	6	
4"	94	22	178	320	190	158	180	220	20	3	18	8	102	M10	8	

Ball Valve

2PC DIN FLANGED BALL VALVE WITH DIRECT MOUNTING PAD(QF203M)

FEATURES

- ◆ DIN PN16-40
- ◆ Full Port
- ◆ Investment Casting
- ◆ Blow-out proof Stem
- ◆ ISO5211 Mounting Pad
- ◆ PED97/23/PE (CE0035) Approved
- ◆ Anti-Static device(option)
- ◆ Design: DIN3357, En12516
- ◆ End Flange: DIN2501, PN10-40
- ◆ Face to Face: DIN3202-F4(DN15-DN100)
- ◆ Inspection Testing: DIN3230/3, EN12266



ITEM	DESIGNATION	QTY	MATERIAL
1	BODY	1	1.4408/1.4308
2	CAP	1	1.4408/1.4308
3	BALL	1	1.4408/1.4308
4	BALL SEAT	2	RPTFE
5	STEM	1	304/316
6	THRUST WASHER	1	PTFE
7	O-RING	1	VITON
8	V-RING PACKING	1	PTFE
9	GLAND	1	304
10	BELIEVILLE WASHER	2	301
11	NUT	2	304
12	THRUST WASHER	1	304
13	WASHER	1	304
14	STOP PIN	1	304
15	HANDLE	1	304
16	HANDLE SLEEVE	1	PVC
17	BODY GASKET	1	PTFE
18	NUT	4-8	304
19	BOLT	4-8	304

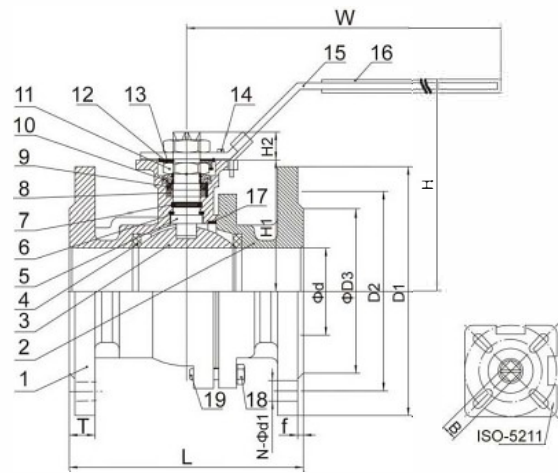

SIZE	d	B	H	W	L	D3	D2	D1	T	f	d1	N	H1	H2	ISO5211	
1/2"	15	11	80	140	115	45	65	95	16	2	14	4	48	8	F04/03	PN16 PN40
3/4"	20	11	95	140	120	58	75	105	18	2	14	4	53	8	F04/03	
1"	25	14	95	160	125	68	85	115	18	2	14	4	58	11	F05/04	
1-1/4"	32	14	105	160	130	78	100	140	18	2	18	4	71	11	F05/04	
1-1/2"	38	17	114	190	140	88	110	150	18	3	18	4	76	14	F07/05	
2"	50	17	124	190	150	102	125	165	18	3	18	4	85	14	F07/05	PN16
2-1/2"	65	17	148	230	170	122	145	185	18	3	18	8	101	17	F10/07	
3"	76	22	158	230	180	138	160	200	20	3	18	8	111.5	17	F10/07	
4"	100	22	190	320	190	158	180	220	20	3	18	8	141	22	F12/10	

Ball Valve

3PC DIN FLANGED BALL VALVE (QF301F)

FEATURES

- ◆ DIN PN16-40
- ◆ Full Port
- ◆ Investment Casting
- ◆ Blow-out proof Stem
- ◆ PED97/23/PE (CE0035) Approved
- ◆ Anti-Static device(option)
- ◆ Design: DIN3357, En12516
- ◆ End Flange: DIN2501, PN10-40
- ◆ Face to Face: DIN3202-F1 (DN15-DN100)
- ◆ Inspection Testing: DIN3230/3, EN12266



ITEM	DESIGNATION	QTY	MATERIAL
1	HANDLE SLEEVE	1	PVC
2	HANDLE	1	304
3	GLAND NUT	1	304
4	STEM NUT	1	304
5	STEM WASHER	1	304
6	STEM PACKING	1	PTFE
7	THRUST WASHER	1	PTFE
8	JOINT GASKET	2	PTFE
9	END CAP	2	CF8/CF8M
10	BOLT	4(6)	304
11	NUT	8(12)	304
12	SPRING WASHER	8(12)	304
13	BODY	1	CF8/CF8M
14	BALL SEAT	2	RPTFE
15	BALL	1	CF8/CF8M
16	STEM	1	304/316
17	LOCKING DEVICE	1	304

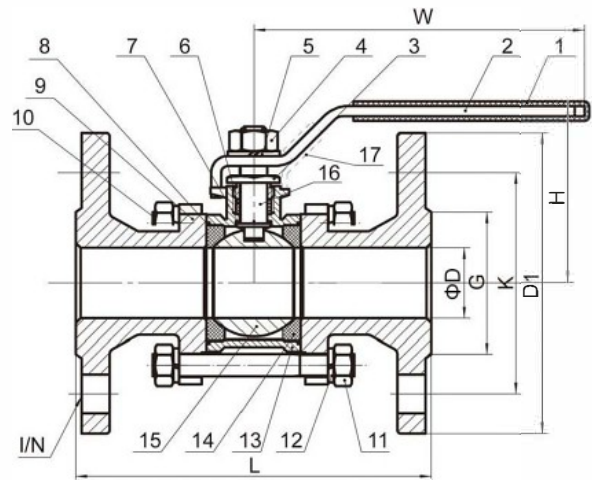

SIZE	D	L	H	W	D1	K	G	I/N
1/2"	15	130	55	103	95	65	45	14/4
3/4"	20	150	61	103	105	75	58	14/4
1"	25	160	61	135	115	85	68	14/4
1-1/4"	32	180	78	135	140	100	78	18/4
1-1/2"	40	200	90	190	150	110	88	18/4
2"	50	230	97	190	165	125	102	18/4
2-1/2"	64	290	143	310	185	145	122	18/4
								18/8
3"	76	310	152	310	200	160	138	18/8
								18/8
4"	100	350	187	400	220	180	158	18/8
								22/8

1/2-2=PN40 2 1/2-4=PN16/PN40

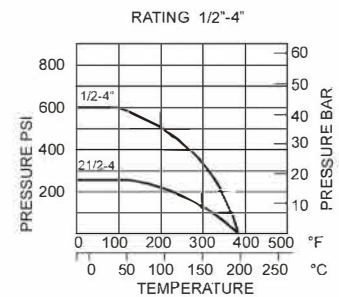

Ball Valve

3PC DIN FLANGED BALL VALVE WITH ISO 5211 MOUNTING PAD (QF301M)

FEATURES

- ◆ DIN PN16-40 ◆ Full Port
- ◆ Investment Casting ◆ Blow-out proof Stem
- ◆ ISO5211 Mounting Pad
- ◆ PED97/23/PE (CE0035) Approved
- ◆ Anti-Static device(option)
- ◆ Design: DIN3357, EN12516
- ◆ End Flange: DIN2501
- ◆ Face to Face: DIN3202-F1 (DN15-DN100)
- ◆ Inspection Testing: DIN3230/3, EN12266

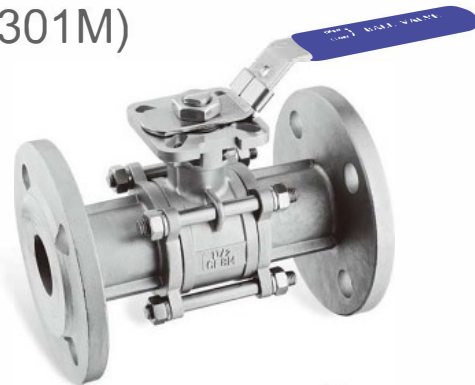

ITEM	DESIGNATION	QTY	MATERIAL
1	BODY	1	CF8/CF8M
2	CAP	2	CF8/CF8M
3	BALL	1	CF8/CF8M
4	BALL SEAT	2	RPTFE
5	STEM	1	304/316
6	THRUST WASHER	1	304
7	O-RING	1	VITON
8	SPRING WASHER	4(6)	304
9	BOLT NUT	4(6)	304
10	STEM PACKING	1	PTFE
11	RING	1	304
12	BELLEVILLE WASHER	1	301
13	LOCK WASHER	1	301
14	STOP PIN	1	304
15	HANDLE NUT	1	304
16	HANDLE	1	304
17	HANDLE SLEEVE	1	PVC
18	WASHER	1	304
19	BOLT	4(6)	304

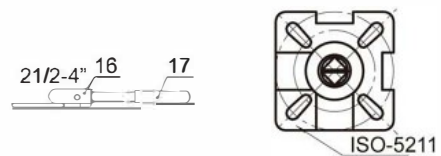
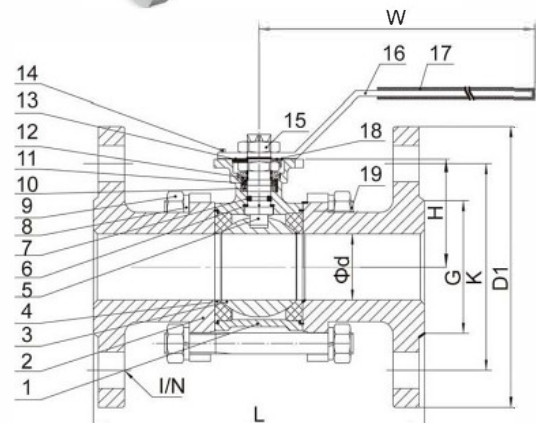

SIZE	d	L	H	W	D1	K	G	I/N	ISO5211
1/2"	15	130	40	140	95	65	45	14/4	F04/03
3/4"	20	150	47	140	105	75	58	14/4	F04/03
1"	25	160	57	160	115	85	68	14/4	F05/04
1-1/4"	32	180	62	160	140	100	78	18/4	F05/04
1-1/2"	38	200	77	180	150	110	88	18/4	F07/05
2"	50	230	86	180	165	125	102	18/4	F07/05
2-1/2"	64	290	108	300	185	145	122	18/4	F10/07
								18/8	
3"	76	310	115	300	200	160	138	18/8	F10/07
								22/8	
4"	100	350	133	400	220	180	158	18/8	F12/10
								235	

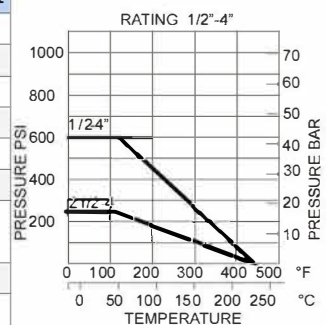

Y-Strainer

Y-STRAINER (QF502)

FEATURES

- ◆ 800PSI(PN40)
- ◆ Investment Casting
- ◆ PED97/23/PE (CE0035) Approved
- ◆ Casting Approved AD2000-W0
- ◆ Thread: ASME B1.20.1 BS21.DIN2999/259, ISO228-1, JIS B 0203, ISO7/1
- ◆ Inspection Testing: DIN3230/3, EN12266

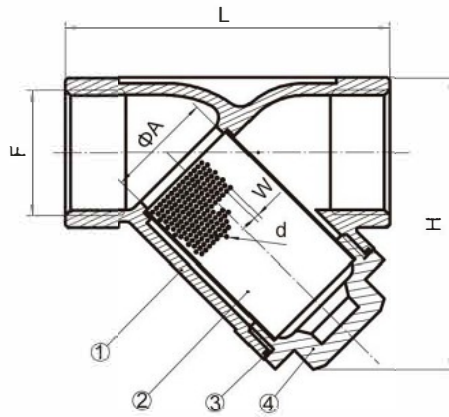
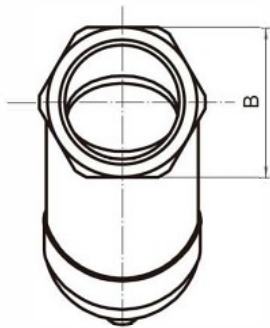

SIZE	A	B	H	L	W	d
1/4"	15	26	58	65	2	1
3/8"	15	26	58	65	2	1
1/2"	15	26	58	65	2	1
3/4"	20	33	68	78.5	2	1
1"	25	41	88	89	2	1
1-1/4"	32	49	100	105	2	1
1-1/2"	40	56	108	120	2	1
2"	50	69	130	140	2	1

ITEM	DESIGNATION	QTY	MATERIAL
1	BODY	1	CF8/CF8M
2	GASKET	1	304/316
3	SCREEN	1	304/316
4	CAP	1	CF8/CF8M

Check Valve

Y-SPRING CHECK VALVE (QF503)

FEATURES

- ◆ 800PSI(PN40)
- ◆ Investment Casting
- ◆ PED97/23/PE (CE0035) Approved
- ◆ Casting Approved AD2000-W0
- ◆ Thread: ASME B1.20.1 BS21.DIN2999/259,
 ISO228-1, JIS B 0203, ISO7/1
- ◆ Inspection Testing: DIN3230/3, EN12266

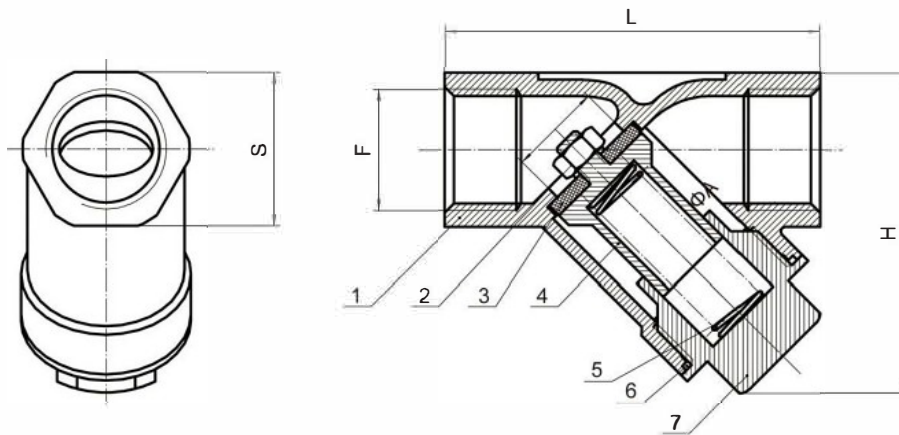

SIZE	A	H	L	S
1/4"	15	58	65	26
3/8"	15	58	65	26
1/2"	15	58	65	26
3/4"	20	68	78.5	33
1"	25	88	89	41
1-1/4"	32	100	105	49
1-1/2"	40	108	120	56
2"	50	130	140	69

ITEM	DESIGNATION	QTY	MATERIAL
1	BODY	1	CF8/CF8M
2	NUT	1	304
3	DISC SEAT	1	PTFE
4	DISC	1	CF8/CF8M
5	SPRING	1	304
6	GASKET	1	PTFE
7	BONNET	1	CF8/CF8M

Check Valve

SWING CHECK VALVE (QF601)

FEATURES

- ◆ 200PSI(PN16)
- ◆ Investment Casting
- ◆ PED97/23/PE (CE0035) Approved
- ◆ Casting Approved AD2000-W0
- ◆ Thread: ASME B1.20.1 BS21.DIN2999/259, ISO228-1, JIS B 0203, ISO7/1
- ◆ Inspection Testing: DIN3230/3, EN12266



MATERIALS LIST

ITEM	DESIGNATION	MATERIAL
1	BONNET	CF8/CF8M
2	GASKET	PTFE
3	BODY	CF8/CF8M
4	HANGER PIN	304
5	PLUG GASKET	PTFE
6	DISC	CF8/CF8M

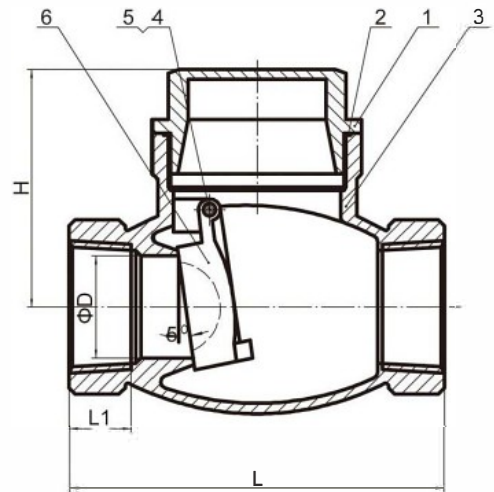

DIMENSION TABLE

ITEM	SIZE	1/4'	3/8'	1/2'	3/4'	1'	1 1/4'	1 1/2'	2'	2 1/2'	3'
D		6	10	15	20	25	32	38	50	62	75
H		42	42	45	53	60	64	76	82	90	100
L		63	63	65	80	90	104	120	141	163	191
L1		10	10	12	15	17	17	20	23	25	28

Globe Valve

GLOBE VALVE (QF801)

FEATURES:

- ◆ 200PSI/PN16
- ◆ Investment Casting
- ◆ PED97/23/EC(CE0035)Approved
- ◆ Casting Approved AD2000-WO
- ◆ Rising stem
- ◆ Thread: ASME B1.20.1
 BS21.DIN2999/259
 ISO228-1,JS B 0203,
 ISO7/1
- ◆ Inspection Testing:API598,EN12266



DIMENSION TABLE

ITEM	SIZE	1/2'	3/4'	1'	1 1/4'	1 1/2'	2'
D		12	15	20	25	32	40
H		87	90	99	118	140	155
D1		70	70	80	80	100	100
L		52	60	71	82	90	101

MATERIALS LIST

ITEM	DESIGNATION	MATERIAL
1	BODY	CF8/CF8M
2	PETAL	CF8/CF8M
3	STEM	304
4	GASKET	PTFE
5	CAP	CF8/CF8M
6	WASHER	304
7	BONNET	CF8/CF8M
8	HAND WHEEL	ALUMINUM ALLOY
9	NUT	304
10	WASHER	304
11	RING	304
12	STEM PACKING	PTFE

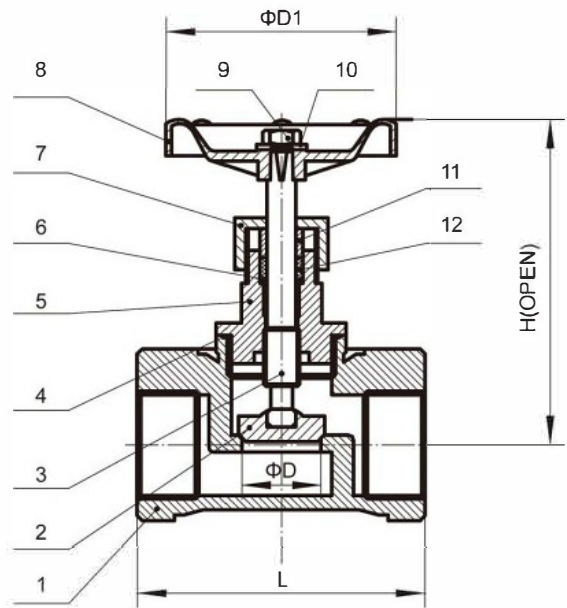

Gate Valve

GATE VALVE (QF901)

FEATURES

- ◆ 200PSI/PN16
- ◆ Investment Casting
- ◆ PED97/23/EC(CE0035)Approved
- ◆ Casting Approved AD2000-WO
- ◆ Non-rising stem
- ◆ Thread: ASME B1.20.1
 BS21.DIN2999/259
 ISO228-1,JS B 0203,
 ISO7/1
- ◆ Inspection Testing:API598,EN12266



DIMENSION TABLE

SIZE	1/2'	3/4'	1'	1 1/4'	1 1/2'	2'
D	15	20	25	32	40	50
H	92	99	113	128	147	168
D1	70	70	80	80	100	100
L	55	60	66	76	86	96

MATERIALS LIST

ITEM	DESIGNATION	MATERIAL
1	BODY	CF8/CF8M
2	BONNET	CF8/CF8M
3	STOP RING	304
4	STEM	304
5	PACKING	PTFE
6	HANDWHEEL NUT	304
7	HAND WHEEL	ALUMINUM ALLOY
8	PACKING NUT	304
9	RING	304
10	LOCK NUT	304
11	GASKET	PTFE
12	DISC	CF8/CF8M

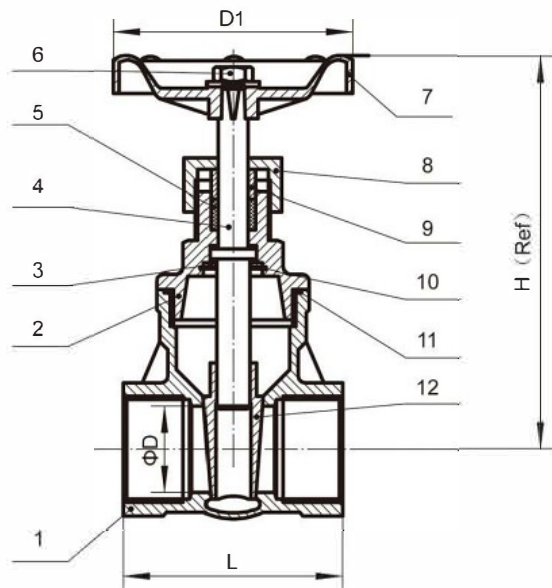

Y-Strainer

Y—STRAINER WITH SMALL PLUG (QF504)

FEATURES

- ◆800PSI(PN40)
- ◆Investment Casting
- ◆PED97/23/PE(CE0035) Approved
- ◆Casting Approved AD2000-WO
- ◆Thread: ASME B1.20.1
BS21.DIN2999/259
ISO228-1,JIS B 0203,ISO7/1
- ◆Inspection Testing:API 598,EN12266

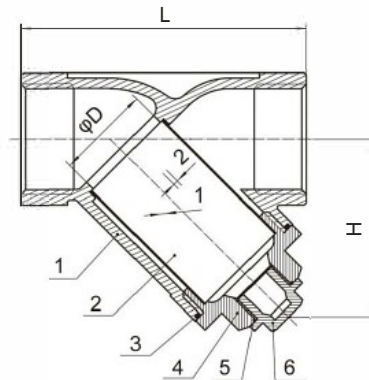
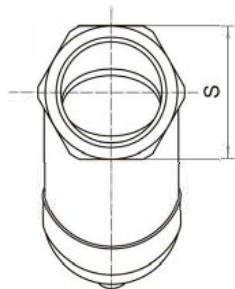

ITEM	DESIGNATION	QTY	MATERIAL
1	BODY	1	CF8M/CF8
2	SCREEN	1	SUS304
3	GASKET	1	PTFE
4	CAP	1	CF8M/CE8
5	GASKET	1	PTFE
6	DISCHARGE PLUG	1	CF8M/CF8

ITEM \ SIZE	1/4-3/8"	1/2"	3/4"	1"	1 1/4"	1 1/2"	2"	2 1/2"	3"	4"
D	12	15	20	25	32	40	50	65	76	94
H	65	65	80	90	104	120	138	183	198	238
L	42	42	51	65	66	75	86	112	123	163

Ball Valve

2PC BALL VALVE M/M (QF213)

FEATURES

- ◆ 1000PSI/PN63
- ◆ Full Port
- ◆ Investment Casting
- ◆ Blow-out proof Stem
- ◆ Locking Device Handle (Option)
- ◆ PED97/23/PE(CE0035) Approved
- ◆ Casting Approved AD2000-WO
- ◆ Thread : ASME B1.20.1
BS21.DIN2999/259,
ISO228-1, JIS B 0203, ISO7/1
- ◆ Inspection Testing : API598 ,EN12266

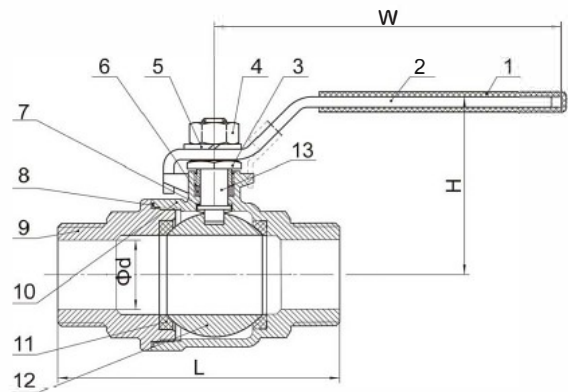
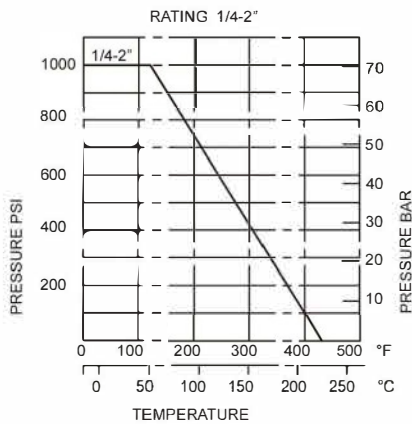

ITEM	DESIGNATION	QTY	MATERIAL
1	PLASTIC SLEEVE	1	PLASTIC
2	HANDLE	1	SUS304
3	GLAND NUT	1	SUS304
4	STEM NUT	1	SUS304
5	SPRING WASHER	1	SUS304
6	STEM PACKING	1	PTFE
7	THRUST WASHER	1	PTFE
8	JOINT GASKET	1	PTFE
9	CAP	1	CF8/CF8M
10	BODY	1	CF8/CF8M
11	BALL SEAT	2	PTFE
12	BALL	1	CF8/CF8M
13	STEM	1	SUS304/SUS316

SIZE	DN	d	L	H	W	S
1/4"	8	8	69	48	91	19
3/8"	10	11.4	71	48	91	21
1/2"	15	13.6	79	52	103	25.5
3/4"	20	18.2	94	61	111	31
1"	25	23	104	65	126	37.5
1 1/4"	32	32	122	79	154	46.5
1 1/2"	38	38	142	83	154	53.5
2"	50	48	168	97	192	66

3PC SANITARY BUTT WELD BALL VALVE (QF305)

FEATURES

- ◆ Standard Port
- ◆ Investment Casting
- ◆ Material : CF8/CF8M
- ◆ Working Pressure : 1000WOG(1/2"-2")
800WOG(2 1/2"-4")
- ◆ Ball Seat : With Cavity Filled PTFE
- ◆ Size Rating : 1/2"-4"
- ◆ End Connections : Tube End(US/3A)
- ◆ Options : Locking Device

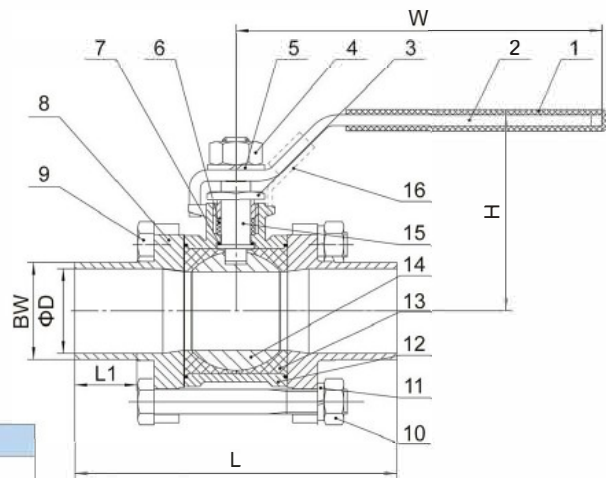
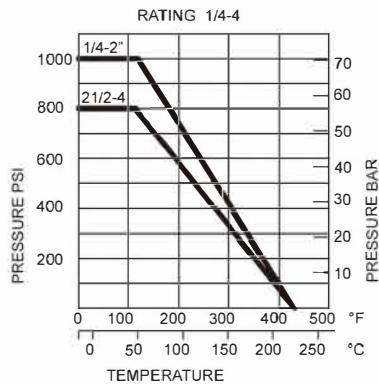

ITEM	DESIGNATION	QTY	MATERIAL
1	PLASTIC SLEEVE	1	PLASTIC
2	HANDLE	1	304
3	GLAND NUT	1	304
4	STEM NUT	1	304
5	STEM WASHER	1	304
6	STEM PACKING	1	PTFE
7	THRUST WASHER	1	PTFE
8	END CAP	1	304/316
9	BOLT	4-6	304
10	NUT	4-6	304
11	SPRING WASHER	4-6	304
12	BODY	1	304/316
13	BALL SEAT	2	PTFE
14	BALL	1	304/316
15	STEM	1	304
16	LOCKING DEVICE	1	304

SIZE	D	L	L1	H	W	BW
1/2"	10.2	82.5	20	55	103	12.7
3/4"	15.8	87.5	20	63	103	19.1
1"	22.1	96	20	70	135	25.4
1-1/4"	28.5	104	20	76	135	25.4
1-1/2"	34.8	118	20	89	182	38.2
2"	47.5	131.7	20	97	182	50.8
2-1/2"	60.2	158.5	20	143	260	63.4
3"	72.9	178.8	20	152	260	76.2
4"	97.4	210.5	20	187	400	101.6

Ball Valve

3PC SANITARY BUTT WELD BALL VALVE WITH DIRECTING MOUNTING PAD (QF305M)

FEATURES

- ◆ Standard Port
- ◆ Investment Casting
- ◆ Material : CF8/CF8M
- ◆ Working Pressure : 1000WOG(1/2"-2")
800WOG(2 1/2"-4")
- ◆ Ball Seat : With Cavity Filled PTFE
- ◆ Size Rating : 1/2"-4"
- ◆ End Connections : Tube End(US/3A)
- ◆ With ISO5211 Direct Mounting Pad
- ◆ Options : Locking Device

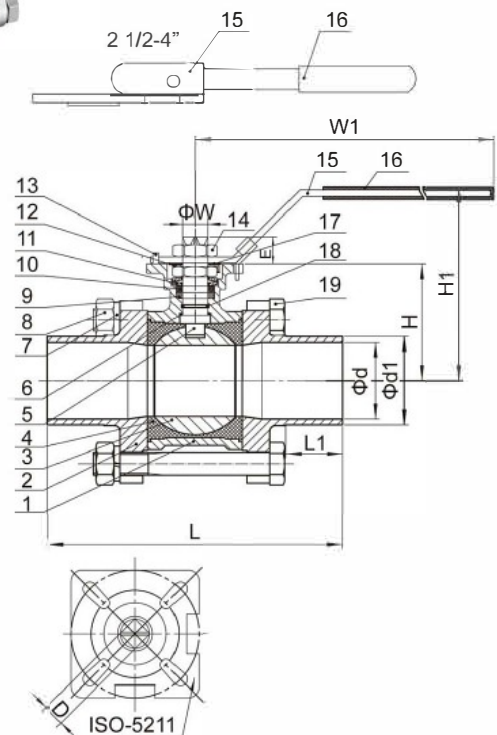

ITEM	DESIGNATION	QTY	MATERIAL
1	BODY	1	CF8/CF8M
2	CAP	1	CF8/CF8M
3	BALL	1	CF8/CF8M
4	SEAT	2	PTFE
5	STEM	1	SUS304
6	THRUST WASHER	1	PTFE
7	SPRING WASHER	4(6)	SUS304
8	BOLT NUT	4(6)	SUS304
9	STEM PACKING	1	PTFE
10	RING	1	SUS304
11	BELLEVILLE WASHER	2	SUS304
12	LOCK WASHER	1	SUS304
13	STOP PIN	1	SUS304
14	HANDLE NUT	2	SUS304
15	HANDLE	1	SUS304
16	HANDLE SLEEVE	1	PLASTIC
17	WASHER	1	SUS304
18	O-RING	1	VITON
19	BOLT	4(6)	SUS304

SIZE	ΦD	ΦD1	L	L1	H	D	E	W	ISO5211	W1	H1
1/2"	10.2	12.7	82.5	20	38	9	9	12	F04/03	143	65
3/4"	15.8	19.1	87.5	20	47	9	9	12	F04/03	143	76
1"	22.1	25.4	96	20	60	11	11	14	F05/04	168	95
1-1/4"	25.4	28.5	104	20	62.7	11	11	14	F05/04	168	95
1-1/2"	34.8	38.2	118	20	79	14	15	18	F07/05	190	115
2"	47.5	50.8	131.7	20	88	14	15	18	F07/05	190	124
2-1/2"	60.2	63.4	158.5	20	109.1	17	17	22	F10/07	350	140
3"	72.9	76.2	178.8	20	116.2	17	17	22	F10/07	350	150
4"	97.4	101.6	210.5	20	142	22	22	28	F12/10	350	175

3PC SANITARY LONG-BUTT WELD BALL VALVE (QF306)

FEATURES

- ◆ Standard Port
- ◆ Investment Casting
- ◆ Material : CF8/CF8M
- ◆ Working Pressure : 1000WOG(1/2"-2")
800WOG(2 1/2"-4")
- ◆ Ball Seat : With Cavity Filled PTFE
- ◆ Size Rating : 1/2"-4"
- ◆ End Connections : Tube End(US/3A)
- ◆ Options : Locking Device

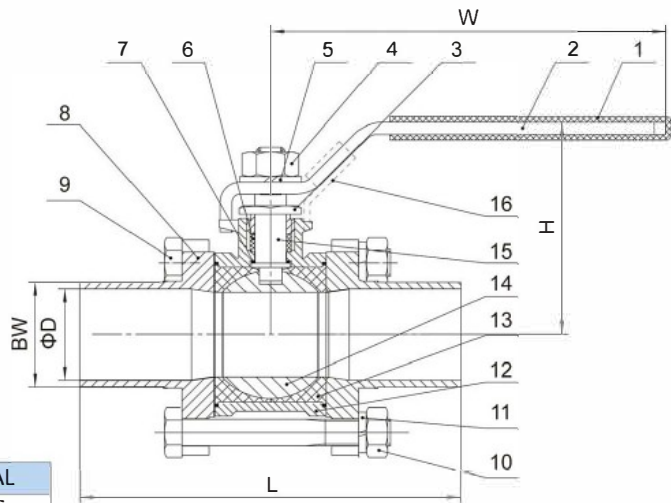
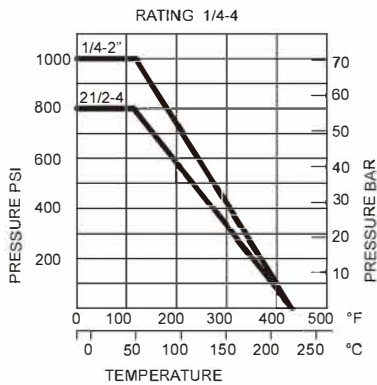

ITEM	DESIGNATION	QTY	MATERIAL
1	PLASTIC SLEEVE	1	PLASTIC
2	HANDLE	1	304
3	GLAND NUT	1	304
4	STEM NUT	1	304
5	STEM WASHER	1	304
6	STEM PACKING	1	PTFE
7	THRUST WASHER	1	PTFE
8	END CAP	1	304/316
9	BOLT	4-6	304
10	NUT	4-6	304
11	SPRING WASHER	4-6	304
12	BODY	1	304/316
13	BALL SEAT	2	PTFE
14	BALL	1	304/316
15	STEM	1	304
16	LOCKING DEVICE	1	304

SIZE	D	L	H	W	BW
1/2"	10.2	135	55	103	12.7
3/4"	15.8	135	63	103	19.1
1"	22.1	152	70	135	31.8
1-1/4"	28.5	157	76	135	25.4
1-1/2"	34.8	190	89	182	38.2
2"	47.5	204	97	182	50.8
2-1/2"	60.2	254	143	260	63.4
3"	72.9	280	152	260	76.2
4"	97.4	306	187	400	101.6

Ball Valve

2PC JIS FLANGED BALL VALVE (QF202FM)

FEATURES

- ◆ JIS 10K
- ◆ Full Port
- ◆ Investment Casting
- ◆ BLOW-OUT Proof Stem
- ◆ ISO5211 Mounting Pad
- ◆ PED97/23/EC (CE0035) Approves
- ◆ Casting Approved AD2000-WO
- ◆ Design: JIS B2002
- ◆ End Flange: JIS B2238
- ◆ Inspection Testing: JIS B2003 API598



ITEM	DESIGNATION	QTY	MATERIAL
1	BODY	1	SCS13A/SCS14A
2	CAP	1	SCS13A/SCS14A
3	BALL	1	SUS304/316
4	BALL SEAT	1	PTFE
5	STEM	1	SUS304
6	STEM PACKING	1	PTFE
7	O-RING	1	NBR
8	V-RING PACKING	1	PTFE
9	GALND	1	SUS304
10	BODY GASKET	1	PTFE
11	NUT	4-8	SUS304
12	BOLT	4-8	SUS304
13	GLAND	1	SUS304
14	STOPPER	1	SUS304
15	SNAPPING	1	SUS304
16	HANDLE	1	SUS304

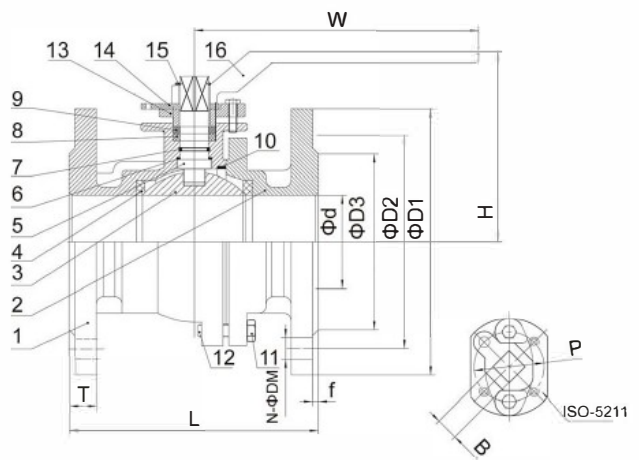

SIZE	d	L	H	W	D3	D2	D1	T	f	M	N	P	B
1/2"	15	108	70	130	51	70	95	12	1	15	4	42	9
3/4"	20	117	76	130	56	75	100	14	1	15	4	42	9
1"	25	127	86	160	67	90	125	14	1	19	4	50	11
1-1/4"	32	140	91	160	76	100	135	16	2	19	4	50	11
1-1/2"	38	165	119	200	81	105	140	16	2	19	4	70	14
2"	50	178	127	200	96	120	155	16	2	19	4	70	14
2-1/2"	65	190	136	200	116	140	175	18	2	19	4	102	17
3"	76	203	164	325	126	150	185	18	2	19	8	102	17
4"	100	229	178	325	151	175	210	18	2	19	8	102	22

Ball Valve

2PC JIS FLANGED BALL VALVE WITH DIRECT ISO5211 MOUNTING PAD (QF202FDM)

FEATURES

- ◆ JIS 10K
- ◆ Full Port
- ◆ Investment Casting
- ◆ BLOW-OUT Proof Stem
- ◆ ISO5211 Mounting Pad
- ◆ PED97/23/EC (CE0035) Approves
- ◆ Casting Approved AD2000-WO
- ◆ Design: JIS B2002
- ◆ End Flange: JIS B2238
- ◆ Inspection Testing: JIS B2003 API598



ITEM	DESIGNATION	QTY	MATERIAL
1	BODY	1	1.4408/1.4308
2	CAP	1	1.4408/1.4308
3	BALL	1	1.4408/1.4308
4	BALL SEAT	2	PTFE
5	STEM	1	SUS304
6	STEM PACKING	1	PTFE
7	O-RING	1	NBR
8	V-RING PACKING	1	PTFE
9	STEM RING	1	SUS304
10	BELLEVILLE WASHER	2	SUS301
11	NUT	2	SUS304
12	THRUST WASHER	1	SUS304
13	WASHER	1	SUS304
14	STOP PIN	1	SUS304
15	HANDLE	1	SUS304
16	PLASTIC COVER	1	PLASTIC
17	BODY GASKET	1	PTFE
18	NUT	4-8	SUS304
19	BOLT	4-8	SUS304

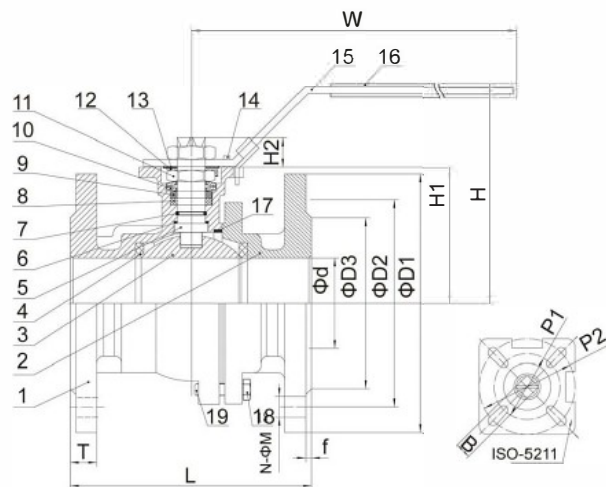

SIZE	d	L	H	H1	H2	W	D3	D2	D1	T	f	M	N	P2	P1	B
1/2"	15	108	80	48	9	130	51	70	95	12	1	15	4	42	36	9
3/4"	20	117	85	53	9	130	56	75	100	14	1	15	4	42	36	9
1"	25	127	100	64	11	160	67	90	125	14	1	19	4	50	42	11
1-1/4"	32	140	108	71	11	160	76	100	135	16	2	19	4	50	42	11
1-1/2"	38	165	114	76	14	200	81	105	140	16	2	19	4	70	50	14
2"	50	178	124	85	14	200	96	120	155	16	2	19	4	70	50	14
2-1/2"	65	190	148	102	17	200	116	140	175	18	2	19	4	102	70	17
3"	76	203	158	112	17	325	126	150	185	18	2	19	8	102	70	17
4"	100	229	189	141	22	325	151	175	210	18	2	19	8	102	—	22

Bibcock Valve

BIBCOCK BALL VALVE (QF201W)

FEATURES

- ◆ 200PSI/PN16
- ◆ Investment Casting
- ◆ PED97/23/EC(CE0035)Approved
- ◆ Thread: ASME B1.20.1
BS21.DIN2999/259
ISO228-1,JIS B 0203,
ISO7/1
- ◆ Inspection Testing:API598,EN12266



SIZE	1/2"	3/4"	1"
D	9	15	20
H	91	102	116
W	92	92	92
L	138	145	158

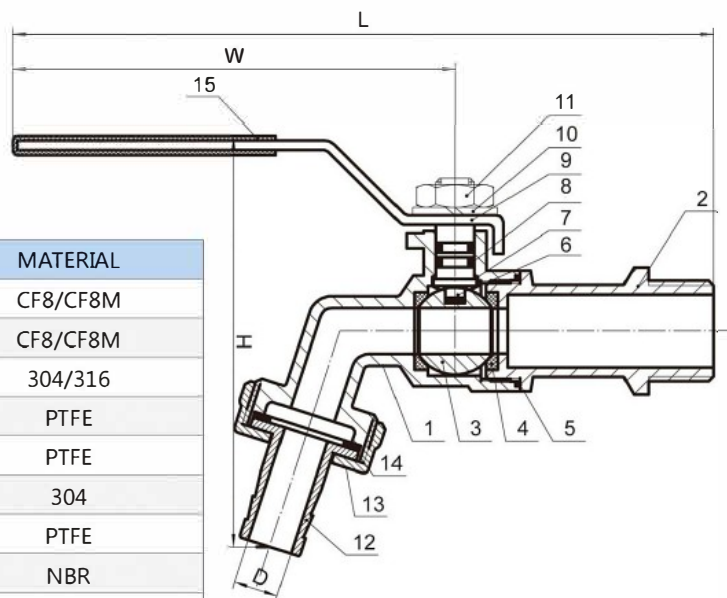

ITEM	DESIGNATION	QTY	MATERIAL
1	BODY	1	CF8/CF8M
2	CAP	1	CF8/CF8M
3	BALL	1	304/316
4	BALL SEAT	2	PTFE
5	JOINT GASKET	1	PTFE
6	STEM	1	304
7	STEM PACKING	1	PTFE
8	O-RING	2	NBR
9	HANDLE	1	304
10	SPRING WASHER	1	304
11	NUT	1	304
12	NIPPLE	1	CF8/CF8M
13	HOSE COMMECTION	1	CF8/CF8M
14	GASKETS	1	NBR
15	HANDLE SLEEVE	1	PVC

Bibcock Valve

POLISHED STAINLESS STEEL BENT BALL COCK WITH BOTTLEFILLER (QF202W)

FEATURES

- ◆ For Food And General Chemical Service Applications
- ◆ Blow-out Proof Stem Design
- ◆ Investment Casting
- ◆ Standard Compliance
 - ASME B 16.34
 - ANSI B 1.20.1
 - API 598
- ◆ Temperature Range: -20° to 450° F
- ◆ End Type: Thread



ITEM	DESIGNATION	MATERIAL
1	BODY	304/316
2	SLEEVE	304/316
3	BALL	304/316
4	SEAL	PTFE
5	STEM	304/316
6	O-RING	NBR
7	LEVER	304
8	SCREW	304

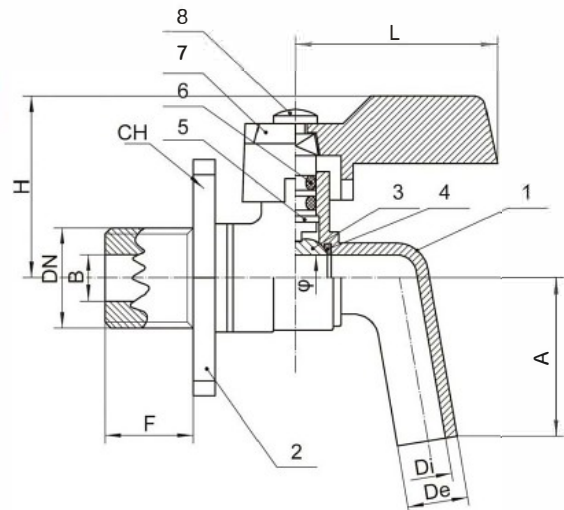

SIZE	B	F	L	CH	S	Di	De	Φ	A	H
1/2"	13	13	38	29	49	8.5	13	10	29.5	36.5
3/4"	20.5	19	38	36	67	14	17	15	38	41.5
1"	25	20	38	43	68	14	17	15	38	41.5

Check Valve

2PC SPRING CHECK VALVE (QF506)

FEATURES

- ◆ 200PSI/PN16
- ◆ Investment Casting
- ◆ PED97/23/EC (CE0035) Approved
- ◆ Casting Approved AD2000/WO
- ◆ Thread: ASME B1.20.1
BS21.DIN2999/259
ISO228-1, JS B 0203,
ISO7/1
- ◆ Inspection Testing: API598,
EN12266



ITEM	DESIGNATION	MATERIAL
1	BODY	CF8/CF8M
2	STEM	SUS304/SUS316
3	SPRING	SUS304/SUS316
4	BOLT	304
5	SEAT	NBR/VITON
6	CAP	CF8/CF8M
7	BODY PACKING	PTFE

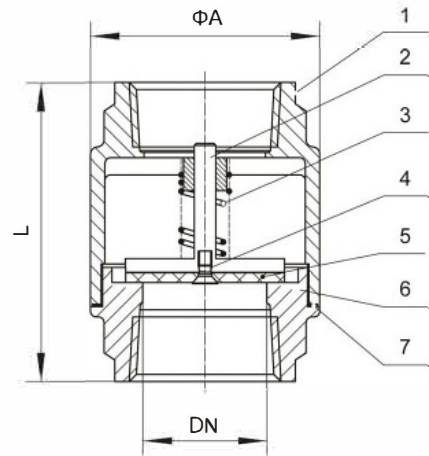

SIZE	1/4"	3/8"	1/2"	3/4"	1"	1 1/4"	1 1/2"	2"	2 1/2"	3"	4"
DN	8	10	15	20	25	30	38	47	61	75	94
ΦA	30.5	30.5	37	42	48	58	70	82	102.5	120	150
L	53	53	56	63	74	81	91	97	118	138	158

Check Valve

3PC SPRING CHECK VALVE (QF507)

FEATURES

- ◆ 1000PSI/PN63
- ◆ Investment Casting
- ◆ Precise Grinding
- ◆ PED97/23/EC(CE0035)Approved
- ◆ Casting Approved AD2000-WO
- ◆ Thread : ASME B 1.20.1
BS21.DIN2999/259,
ISO228-1, JIS B 0203,
ISO7/1
- ◆ Inspection Testing: API598,
EN12266



ITEM	DESIGNATION	MATERIAL
1	BODY	CF8/CF8M
2	CAP	CF8/CF8M
3	SEAL PACKING	PTFE
4	DISC	SUS304/SUS316
5	SPRING	SUS304/SUS316
6	STOPPER	SUS304/SUS316
7	BOLT	SUS304
8	NUT	SUS304

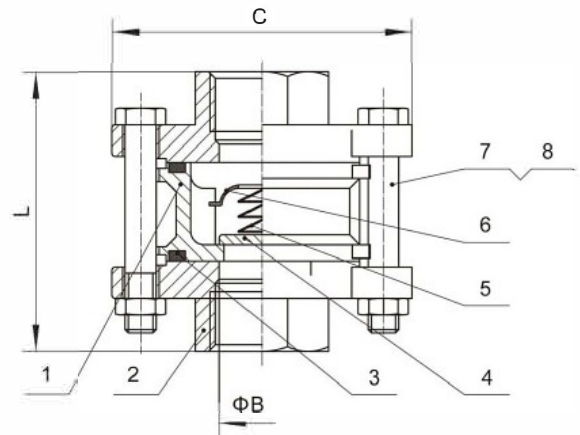

ITEM \ SIZE	1/4"	3/8"	1/2"	3/4"	1"	1 1/4"	1 1/2"	2"	2 1/2"	3"	4"
B	8	10	15	20	25	32	40	50	65	80	100
C	56	56	65	70	78	86	102	118	145	158	185
L	61	61	69	74	80	95	101	114	136	146	174

Check Valve

WAFER CHECK VALVE (QF505)

FEATURES

- ◆ 200PSI/PN16
- ◆ Investment Casting
- ◆ Precise Grinding
- ◆ PED97/23/EC(CE0035)Approved
- ◆ Casting Approved AD2000-WO
- ◆ Inspection Testing: API598, EN12266

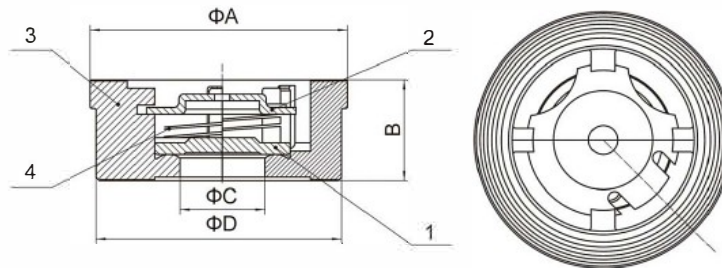

ITEM	DESIGNATION	MATERIAL
1	DISC	CF8/CF8M
2	STOPPER	CF8/CF8M
3	BODY	CF8/CF8M
4	SPRING	CF8/CF8M

ITEM	SIZE	DN15	DN20	DN25	DN32	DN40	DN50	DN65	DN80	DN100	DN120	DN150	DN200
A		39	46	54	70	81	94	113	132	150	187	217	274
L		16	19	22	28	32	40	46	50	60	90	106	140
C		15	20	25	32	40	48	62	75	85	118	140	185
D		34	41	49	62	71	85	102	123	140	177	205	261

STAINLESS STEEL BALL

FEATURES

- ◆ Precision Casting Stainless Steel Ball
- ◆ Forged Stainless Steel Ball
- ◆ Material: CF8, CF8M
- ◆ Manufacturing various types of balls according to customers' requirements

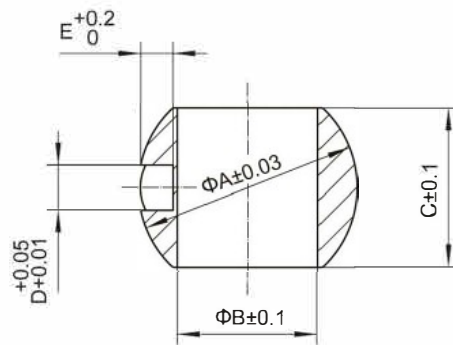
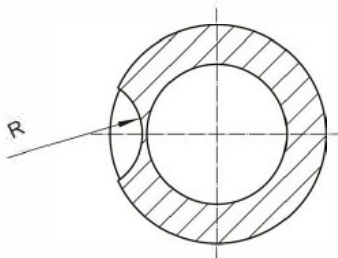

ITEM	SIZE	1/4"	3/8"	1/2"	3/4"	1"	1 1/4"	1 1/2"	2"	2 1/2"	3"	4"
A		15.5	20.5	25.5	32	39	50	60	76.5	100	120	150
B		9	12.5	15	20	25	32	38	50	65	80	100
C		11.5	15.2	19.4	23.7	28.5	36.6	45	56	73.9	86.9	108.5
D		4	4	5	5	8	8	8	9.5	12	12	16
E		2.5	2.7	4	5	5.8	7	8	8.7	12	14	16
F		10	10	13	13.6	19	25	25	28	37.5	37.5	50